



SG-230 Smartuner[®]

Microprocessor Controlled Automatic Antenna Coupler

Installation and Operations Manual



Getting the most from every watt of HF-SSB Power



HF-SSB COMMUNICATIONS: THE POWER TO LOCK IN THE WORLD.

Globally, HF-SSB has literally changed the world. For a minimal investment, it has allowed millions of people - often in amazingly remote settings, often in emergency conditions - to reliably bounce clear voice and data signals across a state, across a continent, over an ocean, or around the world. Without satellites, relay stations, cellular nets, stadium sized antennas or huge user fees. Just some fine equipment, a smart operator and nature's own ionosphere make this possible.

For nearly 30 years, the perfection of HF SSB has been the focus and the life of our company. Our efforts have not gone unnoticed. Today, SGC is a prominent choice of leading corporations, governments, relief agencies, paramilitary organizations, mariners, aviators, explorers, and scientists - all over the world. They trust our engineering and they value our experience.



A vital part of our company's strategy centers around new product development, with an emphasis on providing quality equipment which remains rugged, reliable and competitively priced. We are focused on providing customer service of the highest standard. Our commitment is to product training and comprehensive after sales support. Today, SGC is recognized as a world class designer and manufacturer of HF SSB communications products.

At SGC we build communications power tools. Next generation HF-SSB radios, antennas, amplifiers and coupler systems that squeeze more range and clarity out of every watt of HF SSB communications power, are the technology and innovations that have helped SGC emerge as a cutting edge player in the expanding world of HF-SSB.

Actually, SGC was the first company to perfect and mass produce solid-state HF SSB radios, almost 30 years ago. Today, our focus is an ever higher level of HF SSB refinement and performance. All focused on creating HF SSB voice and data communications systems that are so user friendly and so powerful, they allow every SGC user to easily lock in the world.

Pierre B. Goral, President

SGC SMARTUNER MANUAL

SG-230 SMARTUNER ANTENNA COUPLER

Installation and Operations Manual

Revised: November 2000

Caution: Carefully read the “Quick Start” on the following page and all pertinent sections of this manual prior to operating your Smartuner for the first time. This unit will provide outstanding service if you follow the detailed recommendations within this manual.

Quick Start Guide

To quickly install your antenna coupler you will need the following:

1. An HF radio with 10 to 150 watts output.
2. An HF antenna with a single wire feed (not coax fed).
Minimum length of 8 feet (to 3.5 MHz) or 23 feet (1.8 MHz).
3. A good ground or counterpoise for the antenna and coupler
4. +12 VDC and ground for the coupler.
5. An LED or other indicating device. (Optional)

Connections:

Connect the Smartuner as shown in the following diagram:

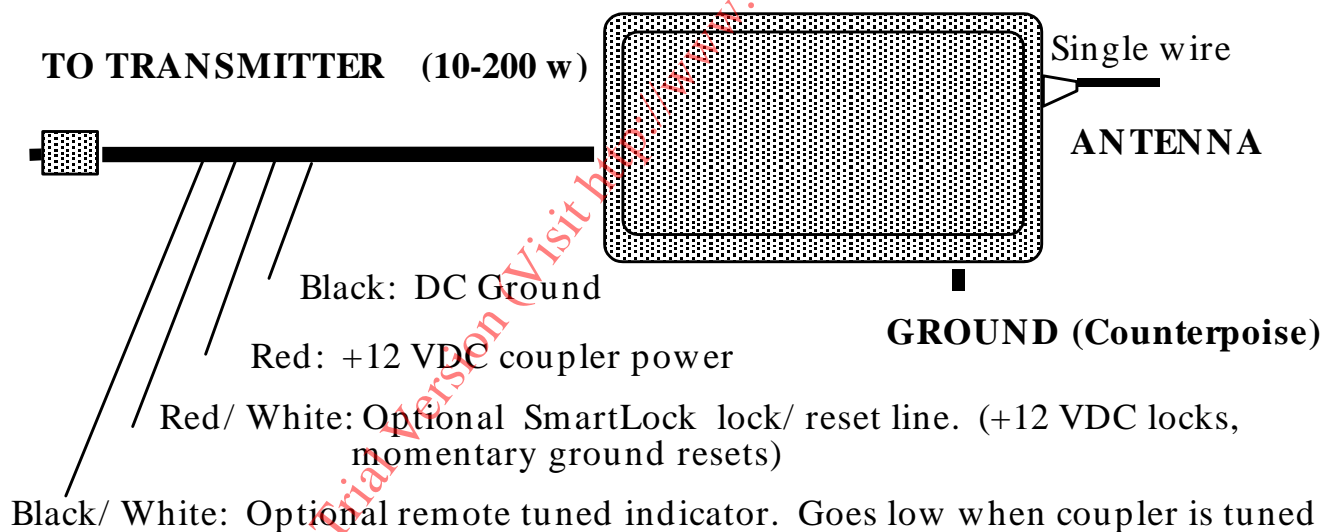

Operation:

1. Turn on Radio. Apply 12 VDC power to the coupler.
2. As power is applied, coupler should make one "click" sound.
3. Coupler should come up in the bypass (untuned) state.
4. To tune, speak normally, whistle or use CW.
5. Tuning should be done at full power. Clicking is heard.
6. When tuned, clicking stops and Black/White wire goes low.

SGC SMARTUNER MANUAL iii

Table of Contents

Quick Start Guide	ii
1.0 General Information.....	1
1.1 Experience Levels of Users	1
1.2 What Is an Antenna Coupler?	1
1.3 Overall Description.....	3
1.4 Coupler Network Configuration	4
1.5 Operation Indicators.....	4
1.6 Mechanical Design	5
1.6.1 Marine Mounting	6
1.6.2 Desert and High Temperature Installations.....	7
1.6.3 Extremely Cold Temperature Installations	7
1.7 Remote Installations.....	7
1.8 Upgrade Sequence.....	8
2.0 Specifications	8
2.1 Accessories	9
2.2 Recommended Antennas	9
3.0 Parts and Technical Support	9
3.1 Parts Furnished.....	9
3.2 User Supplied Items.....	10
3.3 Technical Support.....	11
4.0 Antenna Types.....	11
4.1 Antenna Selection.....	11
4.3 Longwire Antenna	12
4.4 Backstay Antennas	12
4.5 Typical Installations	12
4.5.1 Jeep installation	12

SGC SMARTUNER MANUAL iv

4.5.2 Vehicle installation.....	13
4.5.3 Motor Vessel installation.....	14
4.5.4 Base installation.....	14
4.5.5 Base installation with ground wire radials.....	15
4.5.6 Base dipole.....	16
4.5.7 Base Quadra Loop.....	16
4.5.8 Delta Loop.....	17
4.5.9 Vessel Groundless Loop.....	18
4.5.10 Vessel insulated backstay.....	19
4.6 Apartment Loop Antenna.....	19
4.7 Recreational Vehicle (RV) Antennas.....	20
4.8 Aircraft Antennas.....	21
4.9 Low Profile, Hidden.....	22
4.10 Emergency Antennas.....	24
4.10.1 Kite Antenna.....	24
4.10.2 Tactical Installations.....	25
4.11 Five Golden Rules of HF Installation.....	26
5.0 General Notes on Antennas.....	27
5.1 Steps to Antenna Installation.....	28
5.2 Antenna Location.....	28
5.3 Ground Systems—General.....	29
5.3.1 Vehicle Grounds.....	29
5.3.2 Marine Grounds.....	30
5.3.3 Base Station Grounds.....	31
5.4 Corrosion.....	32
5.5 Antenna Coupler Mounting.....	32
5.6 Antenna Connection.....	32



SMARTUNER MANUAL

v

6.0 Installation Procedures.....	33
6.1 Installation with SG-2000	33
6.2 Installation on all Radios.....	33
6.3 Smartlock Installation.....	34
6.4 Weatherdeck Mounting.....	35
6.5 Electrical Checkout.....	35
6.6 Do-It-Yourself Light-Bulb Dummy Load.....	36
7.0 Coupler Configuration.....	38
7.1 Schematic Diagrams.....	38
7.2 Tuning Process.....	39
7.3 Impedance Detector	39
7.4 VSWR Detector	39
7.5 Phase Detector	40
7.6 Central Processing Unit (CPU).....	40
7.7 Initialization	40
8.0 Tuning Processes and Options.....	41
8.1 Program Description.....	42
8.2 Tuning Paths	43
9.0 Smartlock Operation.....	46
9.1 Tune, Tune Lock, and Reset.....	46
9.2 Smartlock Notes.....	46
10.0 Receiving Antenna	
Systems.....	47
11.0 Troubleshooting the SMARTUNER.....	47
11.1 Ground Faults	48
11.2 Antenna Faults.....	49
11.3 Transmitter Faults	50
11.4 A Final Pointer on Troubleshooting.....	50

SGC SMARTUNER MANUAL vi

12.0 Further Reading.....51
SUBJECT INDEX..... 52

Trial Version (Visit <http://www.aplussofts.com>)

SGC SMARTUNER MANUAL 1

1.0 General Information

The Smartuner™ reputation has grown to legend status because it is simple to use and a highly reliable piece of electronic equipment. A SMARTUNER will provide maximum transfer of radio energy from any HF transmitter to any end-fed HF antenna within the frequency and power limits of its specifications. The SMARTUNER builds upon the renowned reputation of the SG-230 by adding many advanced features, among them: a new, highly technological microcontroller that has built in A/D functions, non-volatile memory, and serial communications capabilities.

This document is designed to guide the SMARTUNER user through installation and operation of the unit. This document will also recommend various steps that may be undertaken in the field to provide correct operation of the SMARTUNER should difficulty be encountered. Smartuners are extraordinarily reliable. But you should be aware that there are scores of fine points to any HF installation that are easily overlooked and may cause difficulty. Our goal in this manual is to help you quickly obtain the best possible performance from your HF radio installation. By reading this manual carefully, you can avoid most of the pitfalls that can degrade the performance of your HF system.

1.1 Experience Levels of Users

The Smartuner may be installed successfully by anyone with the help of this manual. However, if you are inexperienced in HF radio installation and operation, do not be shy about seeking advice from people with more experience than yourself. They will help you achieve good results quickly and with minimum frustration. Even the most experienced professional HF users will occasionally run into difficulty.

Regardless of the level of your experience, SGC stands ready to offer you installation suggestions and help you resolve any aspect of Smartuner operation that is not entirely satisfactory. If you have a specific question, please send us an email or fax at our Bellevue, WA headquarters on the bottom of this page. If you require telephone assistance, please call us between 8:00 A.M. to 5:00 P.M. Pacific Time.

1.2 What Is an Antenna Coupler

Antenna “couplers” are placed at the antenna and precisely match conditions of the antenna to the feed line. Antenna “tuners,” on the other hand, are generally located at the transmitter output at the radio end of the coaxial feed line. Do not be confused by the term “coupler” or “tuner.”

- A tuner placed *at the transmitter* fools a transmitter into working correctly.
- A coupler *installed at the antenna* eliminates feed line losses by providing a

SGC SMARTUNER MANUAL 2

proper match of the antenna to the feed line. The Smartuner is a true antenna coupler.

The several key points, which we will emphasize throughout this manual, will result in the best possible operation of your Smartuner. These include:

- The coupler must be located *at the antenna*.
- No coax may be connected to the coupler output.
- The coupler must have clean +12 VDC power supplied to it.
- The ground system must always be *larger* than the antenna.
- The antenna wire should be of the largest gauge practical.
- Capacitance at the coupler output must be minimal.
- The antenna should be of sufficient length for your lowest operating frequency.

Strictly observing these basic rules will insure good operations under the widest range of conditions.

This manual should be thoroughly studied if you plan to have the best possible signal and most reliable operation of your HF system.

Please make note of the following information for your records:

Date unit was purchased:

Dealer from whom purchased:

Date installed:

Type of antenna used:

SGC SMARTUNER MANUAL 3

1.3 Overall Description

The SMARTUNER is a general-purpose coupler that can operate with any type of radio and almost any type of antenna configuration. The coupler network configuration is of a **pi** or **L** type; sensors continually monitor the state of the tuning and relay this information to the processor.

The initial (first time) tuning may take several milliseconds to a few seconds depending on the complexity of the tuning process for a specific antenna configuration. After tuning the first time for a specific frequency and antenna, this information is entered in the non-volatile computer memory that will store up to 170 tuning solutions.

When the same conditions are encountered again, re-tuning is accomplished within 20 milliseconds by recalling the information from the non-volatile memory. Special software has been designed by SGC to allow accurate and fine-tuning of the coupler. For software description, refer to the MicroTune™ section of the manual.

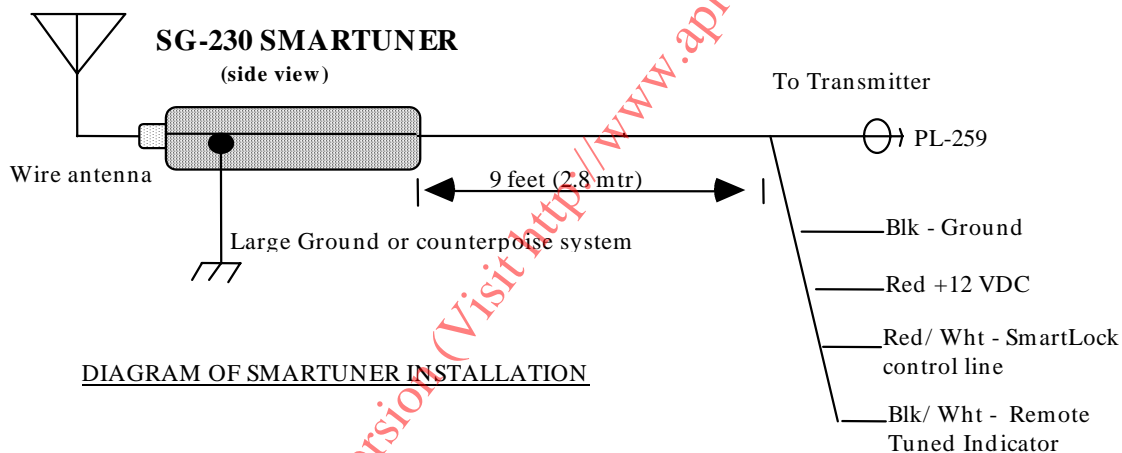

If antenna or transmitter conditions have changed since the information was stored in memory, the coupler retunes and a new tuning solution is achieved. This new information is stored to memory for future reference. The Smartuner will always look for the *best possible tuning solution* and will improve existing tuning solutions whenever possible.

The SMARTUNER may be bypassed and your antenna used as a broadband receiving antenna. To do this, turn off the power to the coupler for two seconds and then turn it back on, or simply press the reset button on the SmartLock. In this situation, the coupler is reset to stand-by waiting for the first RF power to be transmitted before providing a tuning solution. In the stand-by mode, the antenna bypasses tuning elements and connects the antenna directly to the receiver with no tuning elements engaged. This allows for receiving signals throughout the HF range.

SGC SMARTUNER MANUAL 4

The coupler will cease to operate normally if input voltage drops below 10.5v DC. This situation may occur if a marginal battery is used or if you are transmitting at high power with an inadequate power supply or battery. Batteries must be fully charged for proper operation. Large gauge wiring to the transmitter and coupler must be used to avoid retuning.

If broadband operation is required during scanning operations, jumper JP-1 on the printed circuit board inside the coupler may be set to the "YES" mode. This will bypass tuning elements on receive. Jumper JP-1 is located near U1.

In some cases, it may be desirable to re-tune the coupler and bypass the memory information. If you wish to bypass the recalled tuning solutions, place jumper JP-2, also located near U1, to the "NO" position.

1.4 Coupler Network Configuration

The coupler network configuration is designed with 64 different input capacitor values, 32 output capacitor values, and 256 inductor values, thus providing about a half million different pi or L configurations. The coupler requires an input of 3 to 200 watts to operate. The unit operates on +12 VDC and can be optionally supplied to operate at +24 VDC. The +24 VDC option may be installed in the field. Please contact your dealer or SGC and order Part Number 54-52.

1.5 OPERATION INDICATORS

Operational status of the coupler and the onboard computer's tuning decisions is displayed by five LEDs, which are located on the main printed circuit board (PCB). These indicators are only visible when the cover of the coupler is removed. These five LEDs are not designed to be interpreted by other than factory and trained service personnel.

CAUTION: Dangerous high voltages exist inside the Smartuner when it is operated with an HF transmitter. High RF voltages in excess of 10kv may be expected in normal operation of this unit. In addition to shock hazard, these RF voltages may produce burns that are very painful if you come in contact with exposed components. Therefore, DO NOT operate without the cover secured in place unless you are a well experienced radio technician or engineer.

As a matter of good installation and engineering practice, exposed metal antenna elements should be located in such a manner as to prevent accidental contact with people (especially young children), pets, and small animals.

SGC SMARTUNER MANUAL 5

1.6 Mechanical Design

The SMARTUNER is supplied in a weatherproof case with two mounting brackets. RF and DC power are supplied to the unit through the same cable. This special cable consists of a 50-ohm coaxial cable and four conductors. The four conductor wires are for the ground, the positive power lead, the optional SmartLock control, and optional LED indicator.

The SMARTUNER antenna coupler's weatherproof case is designed to withstand the environmental conditions encountered aboard ship when mounted on the weatherdecks. The internal construction is designed to withstand the shock and vibration of marine service. Corrosion-resistant hardware and passive alloys are employed throughout.



We do not recommend opening the SMARTUNER case unless it is necessary. For 99% of installations, the factory settings for jumpers will be correct. Should you have occasion to open the case, use care to ensure the gasket that seals the unit is relocated properly to maintain watertight integrity of the unit.

Although the SMARTUNER is built very solidly, it is good installation practice to provide additional protection from the elements. SGC makes the following recommendations:

SGC SMARTUNER MANUAL 6

1.6.1 Marine Mounting

The SMARTUNER should be located inside the house or under the aft lazaret on a sailboat. On powerboats, the coupler may be mounted outside, but an addition protective housing is recommended. The preferred installation if vertical is with the standoff insulator pointing upward.

A stuffing gland for the RF and DC cables is provided on the lower edge of the weather housing, along with a 1/4-20 stainless steel ground stud. The antenna connects to the ceramic insulator on the top of the weather housing.

The SMARTUNER may be mounted in any position including inverted without any degradation of performance. If the coupler is to be exposed to long periods of high vibration, such as aboard helicopters or tug boats, installation of the optional shock mounting is recommended.

1.6.2 Desert and High Temperature Installations

The SMARTUNER may be used in very hot climates on a continuous basis if some additional protection from direct sunlight is provided. The best protection for a mobile installation is provided by the QMS (Quick Mounting System) that keeps the antenna coupler outside of a vehicle. Temperatures inside a vehicle may exceed 212°F (100°C). If a QMS is not used, it is desirable to keep the coupler in the shade if possible. Please refer to the diagram in the following section.

1.6.3 Extremely Cold Temperature Installations

Your SMARTUNER will operate down to specified temperatures. We recommend placing the SMARTUNER under some kind of housing other than the case to prevent heavy build up of ice. If you are mounting on a tower in a hot or cold climate, a plastic wastebasket (such as those made by Rubbermaid™) makes an excellent weather cover and costs only a few dollars.

SGC SMARTUNER MANUAL 7

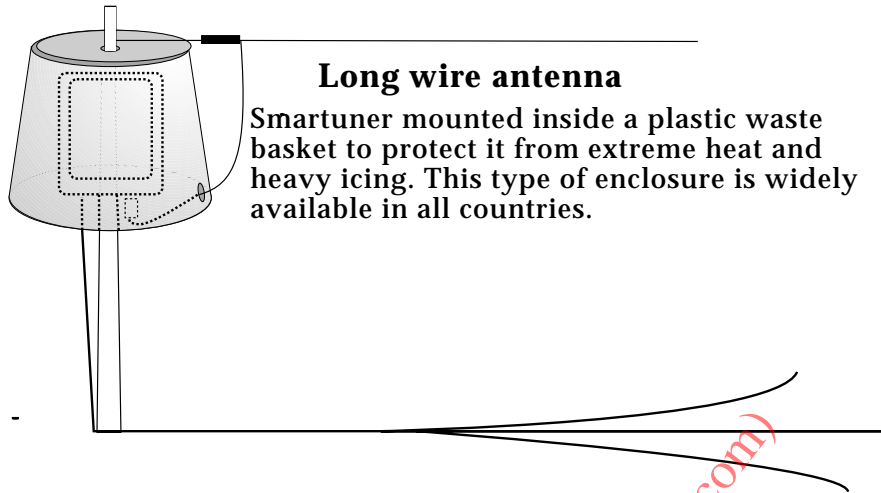

Long wire antenna

Smartuner mounted inside a plastic waste basket to protect it from extreme heat and heavy icing. This type of enclosure is widely available in all countries.

1.6.4 Warranty Note

It is important to have protection from the elements as common weather conditions can reach beyond the capabilities of the coupler. Although the SG-230 coupler is fully waterproof and was created to withstand normal weather conditions, warranty will be voided if left exposed directly to extreme weather such as snow, rain, and ice or prolonged sun exposure. Even in milder climates, direct and constant sunlight can exceed the safe operating temperature and can shorten the lifespan of your coupler.

1.7 Remote Installations

The SMARTUNER is supplied with 9 feet of cable standard. SGC has two standard lengths of antenna extension cable available in the event you need to mount the cable farther than 9 feet from the transmitter. A 25-foot extension cable is available (SGC Part Number 54-65) as is a 50-foot cable (SGC Part Number 54-66).

If you need to install the antenna coupler more than 50 feet from the transmitter site, up to two extension cables may be used for a total of 75 or 100 feet. However, SGC does not recommend installing the Smartuner more than 100 feet from the transmitter because two losses must be considered.

- The first loss in long distance installations is normal attenuation of the radio signal coming from the antenna to the radio via the coax. As you may be aware, the longer the coaxial cable run, the higher the loss will be. The amount of loss is dependent on frequency. At 2 MHz, the loss is approximately .5 dB, while at 30 MHz the loss in 100 feet of coaxial cable is over 2 dB. This means that a 100-watt transmitter would actually deliver about 70 watts to the antenna after running through 100 feet of coax at 30 MHz.

If you are seeking the utmost performance at 30 MHz and you cannot avoid a run of 100 feet, or longer, we recommend using a larger low loss type of coax such as RG-8

SGC Inc. SGC Building, 13737 S.E. 26th St. Bellevue, WA. 98005 USA

P.O. Box 3526, 98009 Fax: 425-746-6384 Tel: 425 746-6310

E-Mail: sgc@sgcworld.com Web Site: www.sgcworld.com

SGC SMARTUNER MANUAL 8

(foam dielectric) or Belden type 9943 coax. Both of these will reduce attenuation to less than 1 dB per hundred feet. You should be aware that this heavier cable is less easy to work and may be quite expensive.

- The second loss which must be considered is the losses in the DC power and reset control line. At any distance other than the 9-foot cable that is supplied by SGC, we recommend that the DC voltage at the antenna coupler be measured because if the coupler voltage drops below 10 volts, the coupler may not operate properly.

For this reason, SGC recommends that if distances are great, the input DC voltage at the transmitter site be adjusted to provide for +12 to +14 volts at the coupler site.

We do specifically advise against use of a different power supply than the one used to power the radio because of the danger of creating ground loops which may cause oscillation of the final amplifiers or other undesired side effects. If you decide to use a separate power supply mounted at the antenna coupler location, please be advised that SGC does not provide technical support in this area.

1.8 Upgrade Sequence

The current version of the SMARTUNER coupler will have a revision letter located on the printed circuit board. To continue moving forward in coupler design, the SMARTUNER may be revised as needed. Later revisions of the coupler will be denoted by the subsequent letters of the alphabet.

SGC will continue making incremental improvements in the SMARTUNER product. When you buy your product today and a new feature is added, you can always upgrade for modest fees to the latest version of the unit. If you would like to upgrade to the latest version of the unit, contact SGC because special discounts are always provided to our valued customers.

2.0 SPECIFICATIONS - SMARTUNER

HF Frequency Range:

1.8 to 30.0 MHz

Note: The SMARTUNER may be operated as low as 1.6 MHz and is commonly used as an antenna-matching unit for differential GPS transmitter site antennas. However, when operated under these conditions, a longer antenna is recommended, such as a 60-foot tower section for operation in the 1700-1710 kHz band and an appropriately larger counterpoise. In addition, inductor heating may become pronounced at high power levels in the SMARTUNER's inductors, which are commonly used at these frequencies. For this reason, we

SGC SMARTUNER MANUAL 9

	recommend 70 watts at 1700 kHz and 50 watts at 1600 kHz on a continuous basis.
Power Input Range:	3 to 200 watts (PEP)
Input Impedance Range:	45 to 55 ohms
VSWR: (Typical)	Typically less than 1.4:1
DC Input Requirement:	+13.8 VDC
DC Operating Range	+10.5 to 15 VDC
Input Current: Average:	.9 amps
Random set time:	Typical: less than 2 seconds
Recurrent set time:	Typical: less than 10 milliseconds
Non volatile memory address:	170
Antenna Length:	Minimum length of 8 ft. —3.5 to 30 MHz Minimum length of 23 ft. —1.8 to 30 MHz
Installation:	Any position
Operating Temperature:	-35° to +70°C
Size:	16 x 12 x 3 inches
Weight:	8 pounds (3.5 kilos)
Case Construction:	Plastic ABS weatherproof case
Control Cable:	SGC special cable, 9 feet coaxial and two power Input wires (plus remote tune LED wire replaceable by any standard cable)

2.1 Accessories

Shock Mounting Tray. SGC Part Number 54-50
+24 VDC Power option. SGC Part Number 54-52
25-foot extension cable. SGC Part Number 54-61
50-foot extension cable. SGC Part number 55-62

2.2 Recommended Antennas

SG-105 Marine and Base station antenna. This is a 60 foot end fed long wire type antenna. SGC Part Number 55-10.

SG-107 Delta Loop Antenna. This is a delta loop 11 meters high by 11 meters wide at the base. SGC Part Number 55-12.

SG-203 Marine 28 foot whip antenna. This antenna is used for most powerboat installations. SGC Part Number 55-24.

SG-303 High performance 9-foot whip antenna. This dual element antenna is designed for severe

SGC SMARTUNER MANUAL 10

marine and land mobile service. SGC Part Number 55-27.

QMS - Quick Mounting System that houses SMARTUNER Smartuner and also provides a sturdy mounting platform for the SG-303 antenna system. Designed for fly away installations requiring no holes installation of high performance HF antenna system. SGC Part Number 55-45.

3.0 Parts and Technical Support

SGC supplies SMARTUNER equipment; the user supplies suitable radio and antenna.

3.1 Parts Furnished

1. Antenna Coupler
2. 9 foot special cable (RG-58 plus 4 conductors in a single jacket.)
3. Instruction Manual

3.2 User Supplied Items

The user of the SMARTUNER will need to supply a suitable HF radio antenna. Such an antenna may be as simple as an 8-foot-long piece of wire and several ground/counterpoise radials of 8 feet or longer. The longer the antenna, up to about 80 feet, the better all around performance will be. Longer antennas may be used, but please refer to the sections on antennas for discussion of limitations.

The user will also have to supply a good counterpoise. Such a counterpoise is a large metal surface (much larger electrically than the antenna). Generally, the bigger the counterpoise, the better your signal will be.

3.3 Technical Support

Before contacting SGC for technical support, please take a few minutes to think through your installation and ask if there is anything obvious that you have overlooked in the installation. Check to make sure your ground system is both adequate and tight and that proper voltage is supplied to the coupler.

In the event you experience difficulty with your SMARTUNER antenna coupler, you should contact SGC for technical advise. Before calling, we ask you to have the following information ready so that we may readily assist you.

SGC SMARTUNER MANUAL 11

Coupler Information. Please have the serial number of your coupler, the name of the dealer from whom the unit was purchased, and the approximate date of purchase.

Antenna Information. Please be ready to describe your antenna installation. You will need to advise us whether the antenna is a wire type, a dipole, V, vertical, long wire, or whip antenna.

Ground System. You should be ready to describe your ground system in detail. If you are dealing with a marine installation, you should have a description of the vessel's bonding system. If you are using the coupler in a mobile setting, you should be able to describe bonding of the hood, trunk, and other vehicle parts that may have been done. In an aircraft, you should be able to describe location of the coupler and type of ground connection used.

Power supply voltage. One of the common mistakes made when installing couplers is to assume that a connection is good when it hasn't been measured. If you experience any type of erratic or intermittent operation, please measure the power supply voltage *inside the coupler*.

Describe Coupler behavior. If you are having a problem, determine if it is happening all the time or only part of the time. Does the problem occur only on certain frequencies? Does the problem happen only in certain modes?

Be patient. Finding the reason for less than ideal system operation may take one telephone call or it may take several calls. Regardless of how complex the problem is, your SGC representative will be able to walk you through the process of solving your problem in a logical step-by-step manner. The Smartuner

and accessories will always give top performance when carefully installed. **4.0**

Antenna Types

The automatic antenna coupler is designed for use with end-fed unbalanced antennas such as whips and long wires. The radiating portion of the antenna is connected directly to the coupler through a high voltage insulator. It is extremely important that the antenna type, site location, and grounding technique be correctly chosen so that the system will radiate effectively.

Wideband antennas (e.g., log periodic) that cover the full range of the system may be used with the coupler if desired. Narrow band resonant antennas, such as dipoles, Vs, and inverted Vs may only be used if the antenna VSWR (including coaxial feeder) is less than, or equal to 3:1 at the operating frequency.

Note that if a dipole or V type antenna is used, the antenna may be operated at any frequency within the range of the coupler if each side of the V or dipole is 23 feet or

SGC Inc. SGC Building, 13737 S.E. 26th St. Bellevue, WA. 98005 USA

P.O. Box 3526, 98009 Fax: 425-746-6384 Tel: 425 746-6310

E-Mail: sgc@sgcworld.com Web Site: www.sgcworld.com

SGC SMARTUNER MANUAL 12

longer. In addition, the SMARTUNER is just as happy feeding a conventional V antenna as an inverted V. The coupler is flexible in this regard.

4.1 Antenna Selection

The automatic antenna coupler will operate into almost any end-fed antenna with a length of 2.5 meters or more, provided an effective ground is used. The antenna efficiency will generally be proportional to length and in most applications will be maximum at a length of 1/4 wavelength. This means that the longest possible antenna should be selected for each installation.

Very short antennas are only recommended when there is no other alternative such as in a vehicular mobile installation. The performance of short whip antennas is usually very poor, particularly at the lower frequencies, and radiation efficiency will be only a few percent of a full sized antenna. However, a special electrically long antenna such as the SG-303 9-foot antenna overcomes the radiation problem.

4.2 Whip Antennas

2.5 to 3.0 Meters (8 to 9 feet)

This antenna is recommended only for vehicular mobile installations. The short length will result in poorer performance compared with the longer antennas. A special high performance 9-foot antenna, the SG-303, is manufactured by SGC specifically for this problem. (SGC Part Number 55-27.)

7.0 to 8.5 Meters (28 feet)

This antenna is recommended for marine installation on smaller vessels. It may also be used in base stations if there is no way of using a longer antenna. The SG-203 is this type of antenna. (SGC Part Number 55-23.)

10.7 Meters (35 feet)

This is the preferred antenna for marine installation when there is no room for a longwire antenna. It will also provide reasonable efficiency for base station use and is the shortest recommended base antenna. (SGC Part Number 55-24 for the SG-204 35 foot whip antenna.)

4.3 Longwire Antenna—23 Meters (75 feet); 46 Meters (150 feet)

For most applications, the longwire antenna will give the best results and is recommended when practical. The diagrams at the end of this section show some recommended methods of installation. These are only a few of the many possible methods of installation, and frequently a different configuration will be the best at a

SGC SMARTUNER MANUAL 13

particular site. SGC's long wire antenna, 60 feet in length, provides efficient operation on low frequencies and high frequencies alike. (SGC Part Number 55-10.)

4.4 Backstay Antennas —8 Meters (28 feet) and Longer

Although we would love to sell everyone a high performance marine whip antenna, the backstay of a sailboat is almost impossible to improve upon in most installations.

4.5 Typical Installations

Figures 4.5.1 through 4.5.11 show some typical installations for the automatic antenna coupler.

Figure 4.5.1 Jeep installation

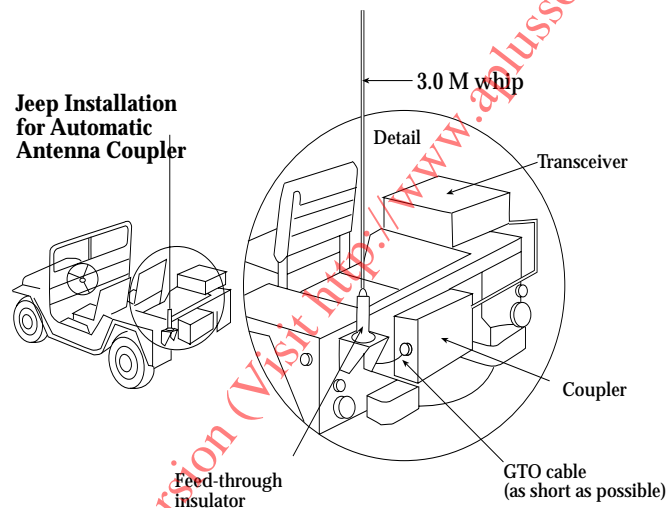

Figure 4.5.2 Vehicle installation

SGC SMARTUNER MANUAL 14

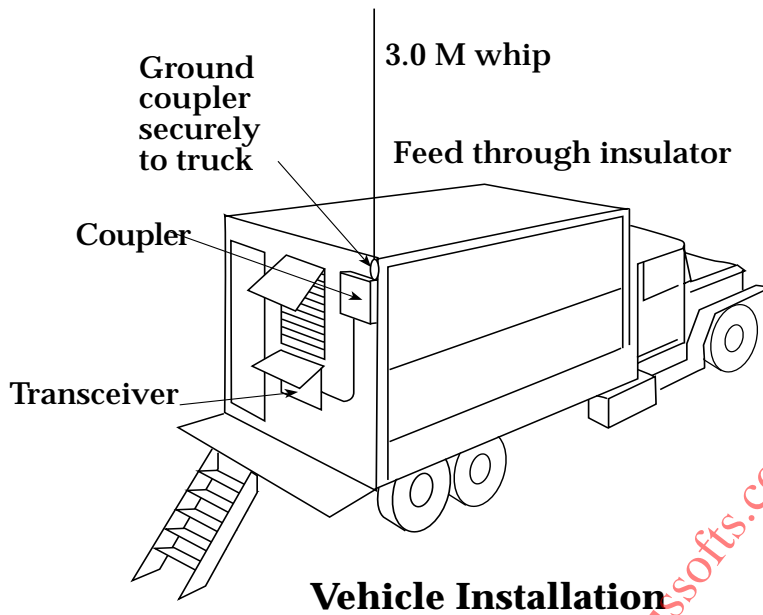

Figure 4.5.3 Motor Vessel installation

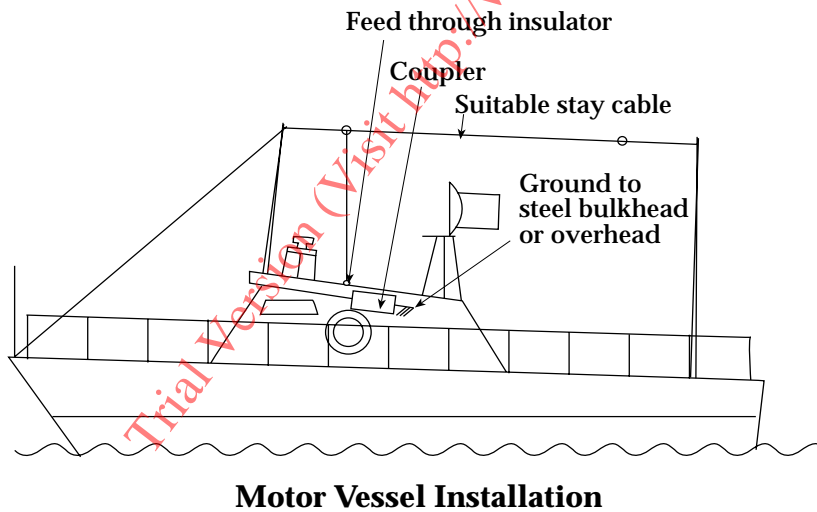
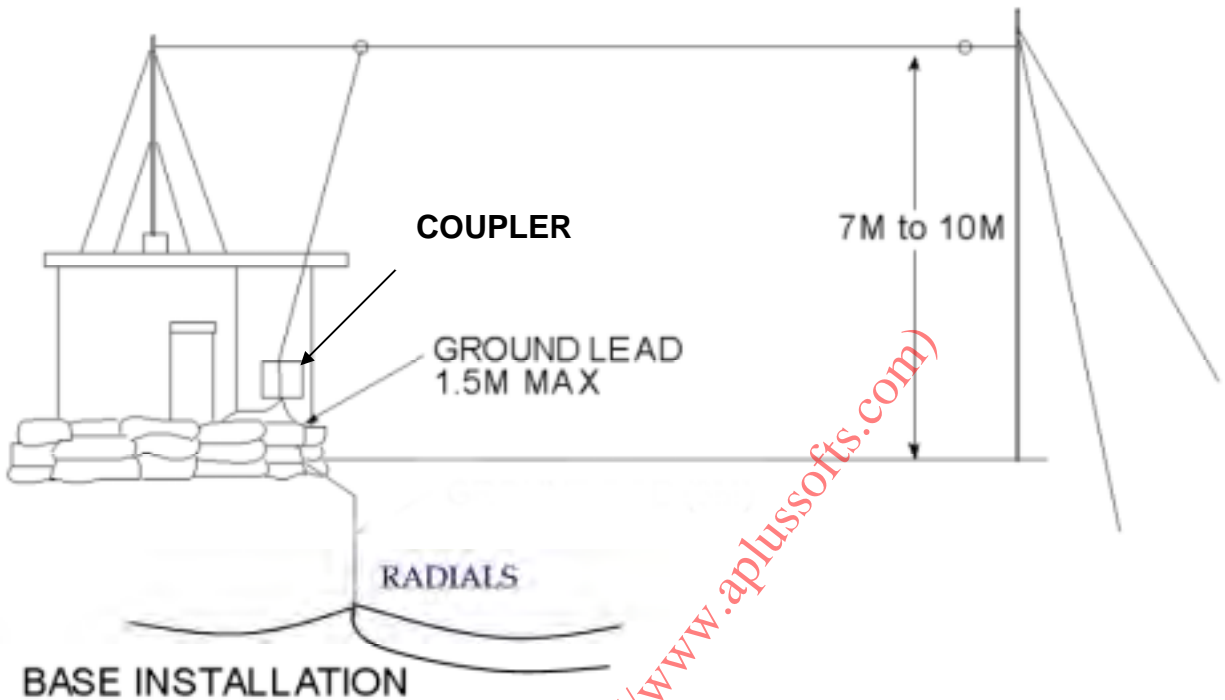

Figure 4.5.4 Base installation**Figure 4.5.5 Base ladder installation**

Trial Version (Visit <http://www.aplussofts.com>)

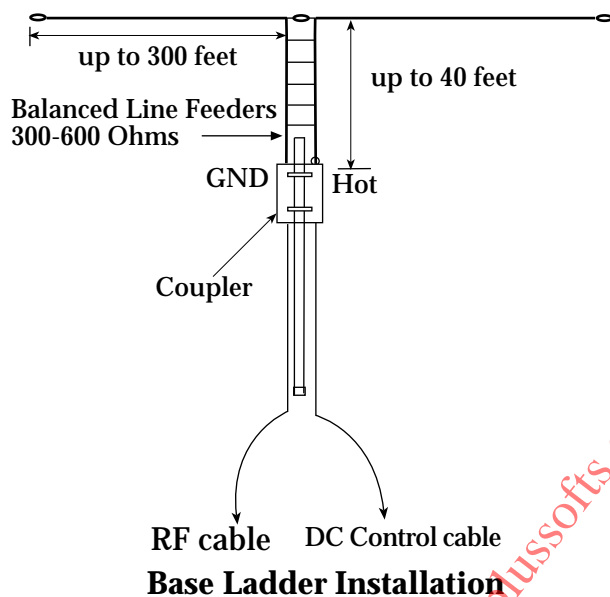

Figure 4.5.6 Base installation with ground wire radials

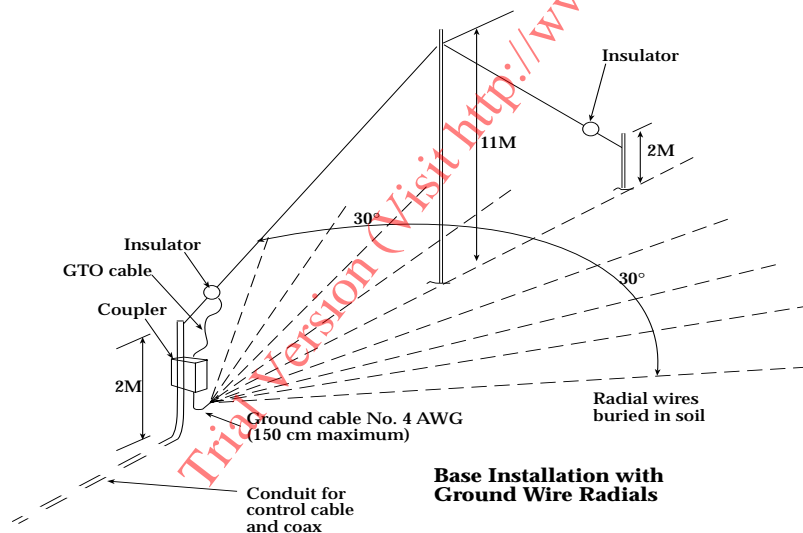

Figure 4.5.7 Base dipole installation

SGC Inc. SGC Building, 13737 S.E. 26th St. Bellevue, WA. 98005 USA

P.O. Box 3526, 98009 Fax: 425-746-6384 Tel: 425 746-6310

E-Mail: sgc@sgcworld.com Web Site: www.sgcworld.com

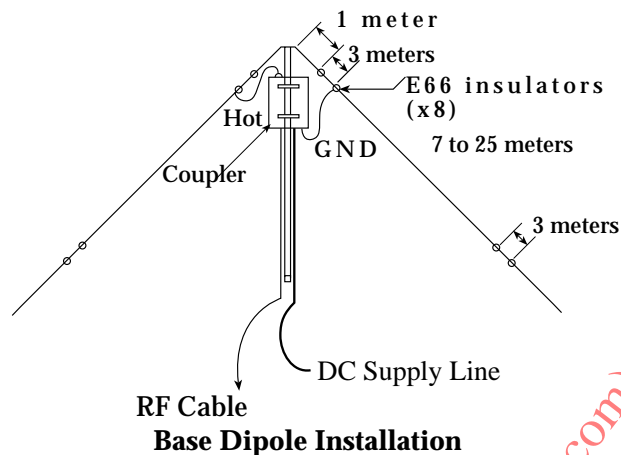
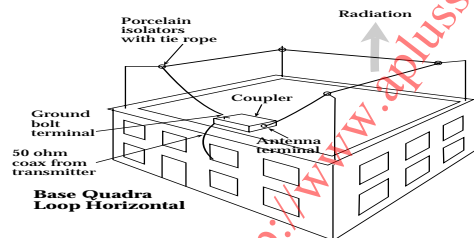

Figure 4.5.8 Base Quadra Loop Horizontal



The horizontal quad loop is a groundless antenna for high angle radiation and is ideal for HF communications up to 500 miles in the frequency range of 2 to 10 MHz. This configuration provides optimum near-right angle reflection to the ionosphere for short-range communications.

A square base can be from 8 to 15 meters long and can be configured to the shape of the structure as necessary, to provide the best arrangement. The height of the supporting poles should be 20 to 40 feet. Supporting poles should be as tall as possible to provide the antenna with the greatest isolation from industrial noise generated by the building, such as fluorescent lights and electrical motors. Loop antennas are also less susceptible to industrial RF noise generated by the building, because they are isolated from the ground system of the building.

Loop wires are attached at one end on the high voltage active side of the coupler and on the other end at the ground side of the coupler.

Figure 4.5.9 Base Delta Loop

SGC SMARTUNER MANUAL 18

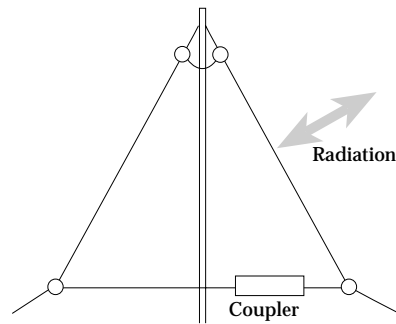

Base Delta Loop

The delta loop antennas are ideally suited to long range communications due to their low angle. This configuration is best for communications ranging from 500 to 5000 miles in the HF frequency range of 4 to 22 MHz. Noise rejection is excellent, as stated for the quad loop antenna. Because the antenna system is not connected to a ground, noise rejection is enhanced. If mounted on the rooftop of the building, it is further isolated from the building, which generates RF noise.

The supporting mast should be 8 to 14 meters tall to provide good overall HF performance.

Note that with this type of antenna, the coupler may be mounted in the middle of the horizontal portion of the loop or it may be mounted at the corner. If mounted at the corner and the lead from the coupler attached to the vertical leg, the polarization of the loop tends to be vertical and is slightly better for low angle long distance communications.

Loops in the horizontal plane may also be used. This type of antenna provides exceptionally good performance on the low frequency bands for short to intermediate range communications.

Figure 4.5.10 Vessel Groundless Loop

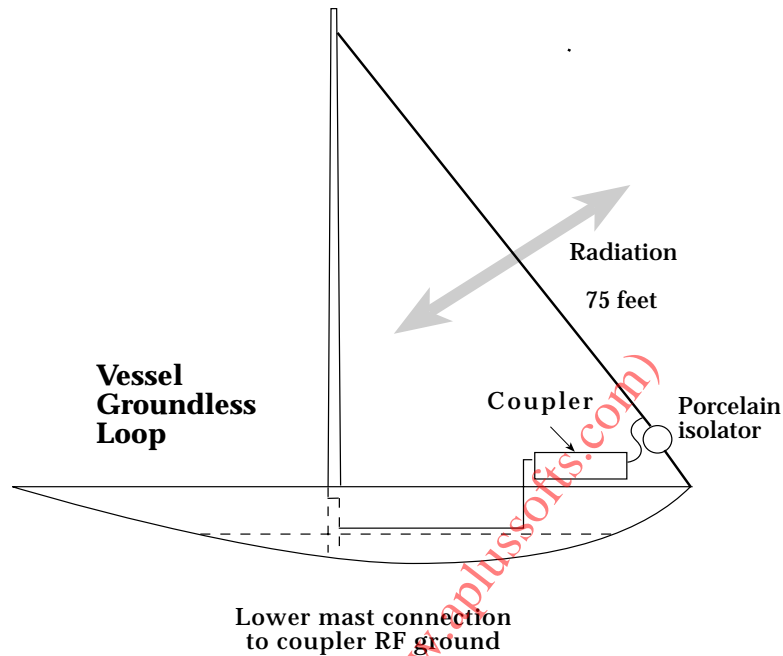

The triangular loop antenna for sailboats is designed to operate in a groundless environment and still provide high performance. This type of installation will require only one insulator point on the bottom back stay and an electrical connection on top of the mast and the stay. The grounded side of the coupler should be connected to the bottom of the mast. Although not our best recommendation, this antenna will provide a workable solution in some installations.

SGC SMARTUNER MANUAL 20

Figure 4.5.11 Vessel insulated back stay

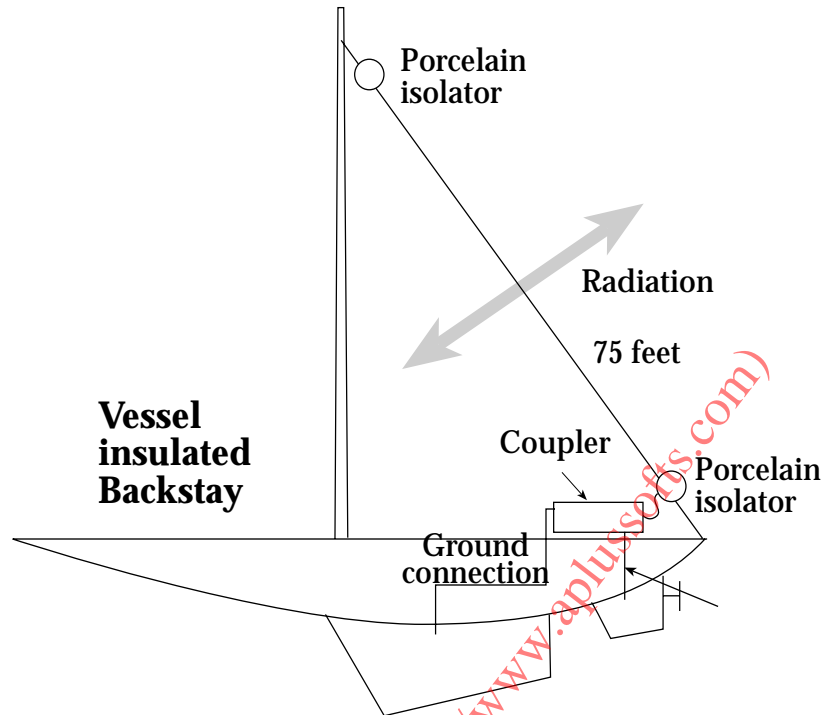

The insulated back stay antenna requires two porcelain isolators. The coupler must be placed as close as possible to the base of the back stay antenna. Proper grounding of the coupler is very important. Connect the RF ground terminal of the coupler to all of the metal parts or structures of the boat (keel, engine, etc.).

4.6 Apartment Loop Antenna

Loop antennas can be used very effectively in small apartments, offices, and rooms. Radiation for a loop antenna is always efficient but highly directive. Therefore, the orientation of the loop is very important. Generally, the vertical loop antenna with horizontal radiation is much preferred for a general application throughout the 1.8 to 30 MHz band. However, loop antennas can be effective when mounted horizontally to the ground to radiate vertically and provide efficient short-range communications on higher frequencies. Generally HF connections are difficult to establish in the distance range of 50 to 250 miles. In a large room (such as 20 x 30), we would recommend the installation of a single wire loop antenna mounted on the ceiling with the coupler against the wall directly below the antenna. The wire gauge should not be less than 16 AWG with insulation.

When operating in a small room, install a small multiple wire loop (six loops) on a rectangular configuration three by four feet (as illustrated in Figure 4.6.1). This configuration allows operation from 1.8 to 60 MHz, and the SG-231 will tune and load

SGC SMARTUNER MANUAL 21

all frequencies well below a ratio of 1.4:1 VSWR. Directivity will be high from 3 to 12 dB depending upon the frequency. If this is a problem, two loops at 90 degrees can be installed to communicate at 90 degrees off direction of the first loop antenna. Loop antennas are low noise antennas. However, because they are used in apartments and crowded cities, high industrial noise can be expected. Avoid using neon or fluorescent lights within 50 feet of the loop antenna, as they may completely jam one or several frequency bands.

Figure 4.6.1 Small loop antenna (3x4 feet)

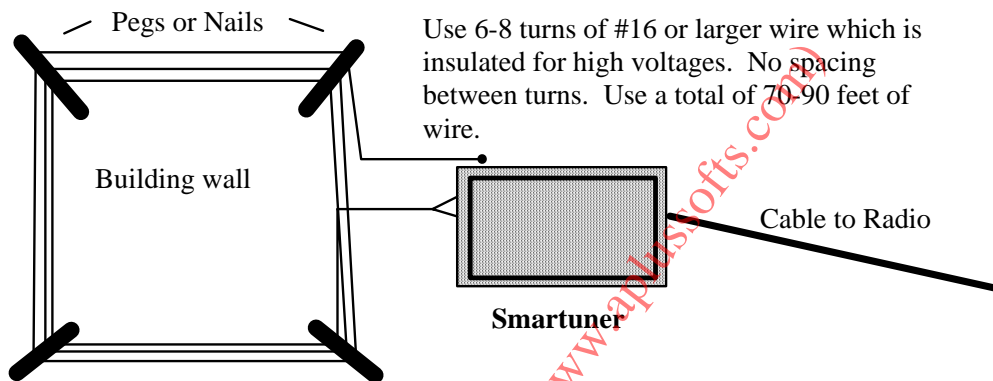

Loop antennas of much larger sizes can be used; however, while the low frequency operation of such antennas may be quite good, the larger antennas may not work well at very high frequencies when located in a plane parallel to the earth. This is because large loop antennas generally radiate their maximum lobe (field strength) at right angles to their plane.

This means that a large loop, say 60 feet on a side, mounted 20 feet above the ground, would radiate much of its energy upward. While during the day this would work well for close in communications, longer distances would be achieved with the loop mounted vertically. The vertical loop antenna of 1/4 wavelength is the basis of the “quad” type directional antenna.

Loop antennas represent a closed circuit and for this reason are much less susceptible to noise or RF contamination than other kinds of antennas. In certain residential and industrial areas where high noise levels occur, the loop antenna may provide a substantial improvement in receiving and transmitting performance at very little cost.

4.7 Recreational Vehicle (RV) Antennas

RVs or trailers provide an excellent base to install effective low cost antennas, and in both configurations, end feed or loop antennas can be used.

An end-fed antenna could be effectively used if a metal cabin structure is available. Loop antennas have the advantage of not requiring a ground system but are highly

SGC SMARTUNER MANUAL 22

directive. The antenna can be mounted simply on short (18" long by .5" diameter) plastic plumbing pipes. Make the end-fed antenna as long as possible in an "L" shaped configuration, as illustrated in Figure 4.7.1.

Figure 4.7.1 Recreational vehicle, bus, or truck detail

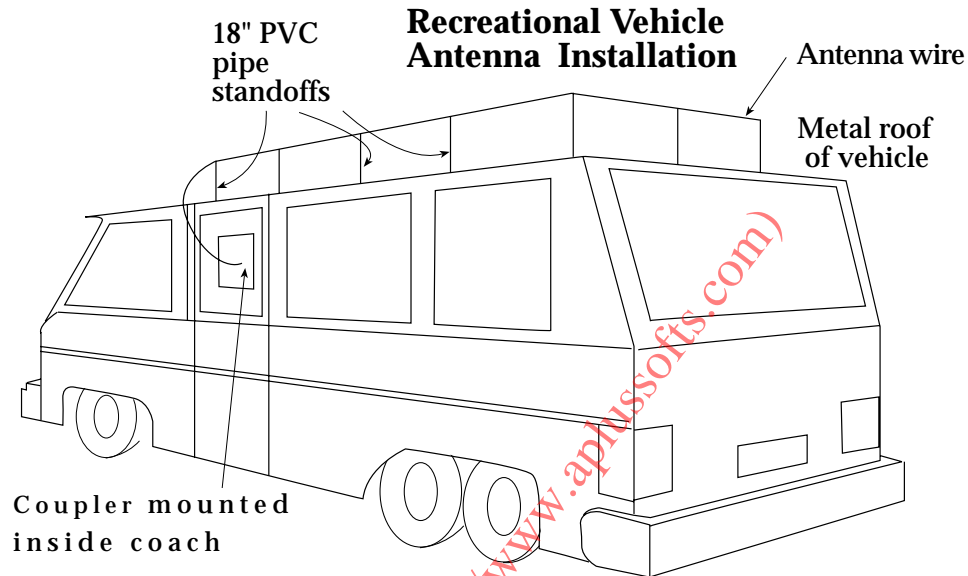

Use a separate ground strap or wire for the body and the chassis to the ground of the coupler.

4.8 Aircraft Antennas

When installed in high performance turboprop or jet aircraft, the Smartuner will operate well with a shunt-fed antenna.

This is generally a 13-foot piece of metal that mounts on the fuselage of the aircraft and is grounded to the aircraft at one end. The device looks something like a towel bar on the underside of the aircraft.

The Smartuner will also match well the more common wire antenna from fuselage to vertical stabilizer (and continuing to a wing tip, if desired) and a long wire antenna under the tail rotor of helicopters. This long wire approach has proven effective on Bell Jet Rangers and Long Rangers in particular.

Figure 4.8.1 Aircraft installation detail

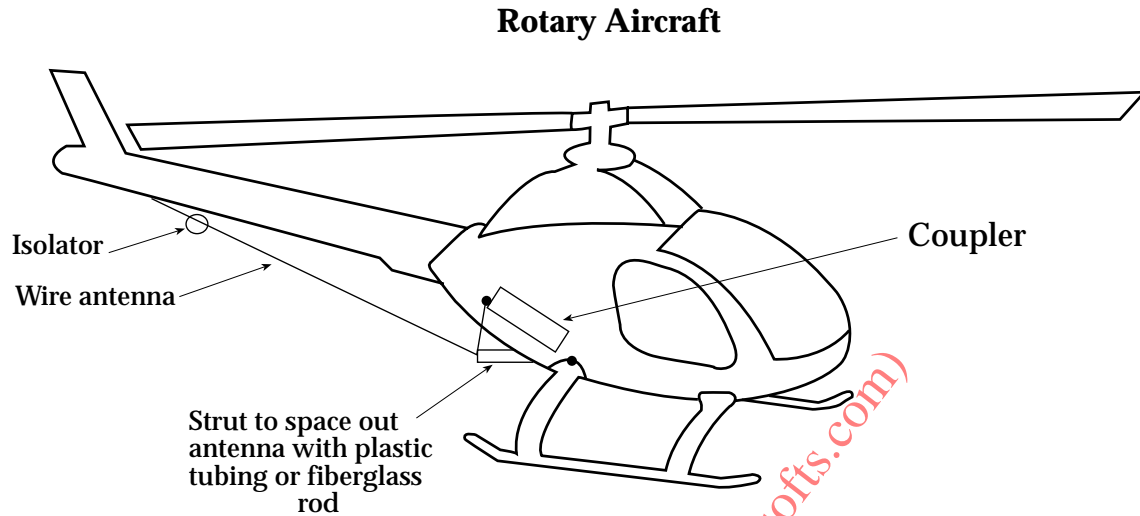
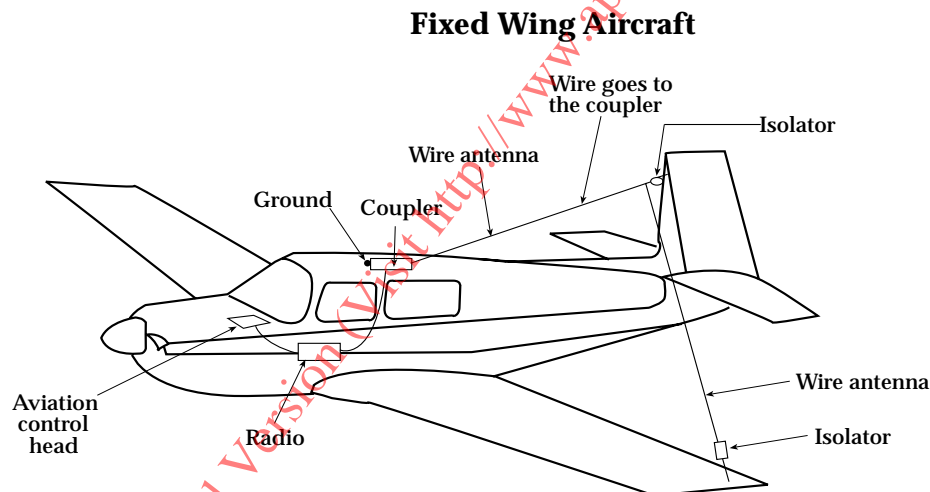

Figure 4.8.2 Aircraft Installation Detail



4.9 Low Profile, Hidden and Covert Antennas

There are two users of low profile, hidden, and covert antennas:

- The paramilitary user who will wish to operate from a residence or commercial building without drawing attention to long range HF communication in progress.
- Commercial building without drawing attention to the fact that long range HF communication is in process.
- The amateur radio community (a larger group) finds itself more restricted by covenants, building codes, and tenant requirements.

SGC SMARTUNER MANUAL 24

In a typical residential building, covert antennas have been used successfully for intercontinental communications. The antennas used include both groundless loop type antennas and those that require a counterpoise (ground).

A. If a flagpole is made of PVC pipe, it is easy to tape a large gauge wire to the inside of the pipe and use a good counterpoise. Typical flagpoles are 25 to 35 feet in height and offer excellent performance on all bands.

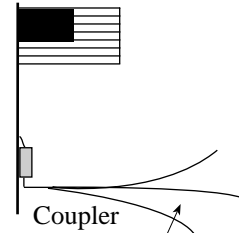

At least three ground radials longer than the flag pole

B. Masonry chimneys are visually "busy." You can run a #10 copper wire parallel to the chimney with little risk of detection. Some short standoffs and you have a support for a vertical dipole type antenna.

C. Along the edge of the roof, held off by some inexpensive TV twin-lead standoffs, you can hide 25 to 40 feet of antenna on virtually any house.

D. The Inverted "L" antenna may work slightly better if it is installed clear of a building, but for covert operations, this type of installation is a favorite. If the feed-point is at ground level adjacent to an iron or copper water line entering the house that could provide an excellent counterpoise but it is not recommended as radials. Ground wire will always insure proper and better grounding.

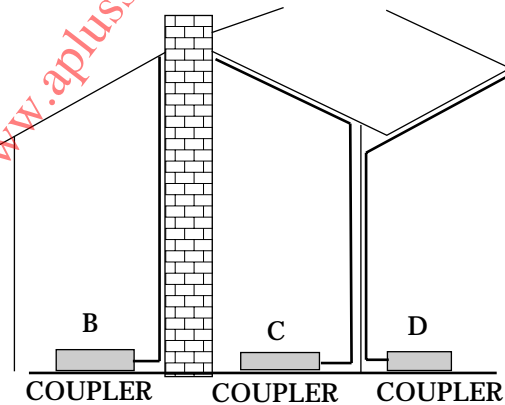

SGC SMARTUNER MANUAL 25

E. Under the roof overhang, all kinds of wire antennas may be installed.

F. All types of antennas may be hidden inside the roof of a building that uses non-metallic roofing materials.

G. The downspout, rain gutter antenna works well if the piping and gutter are aluminum. You may wish to assure low electrical resistance connections between gutter sections with hose clamps or plumber's tape.

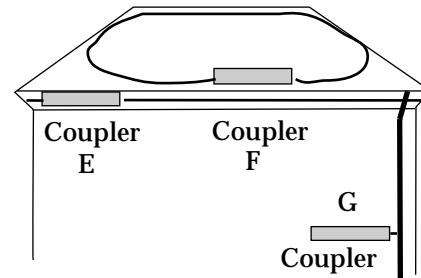

4.10 Emergency Antennas

There are a couple of antennas which don't fit into any category in particular, but which should be mentioned because when used with a Smartuner, they will deliver spectacular results.

4.10.1 Kite Antenna

Figure 4.10.1 Kite Antenna

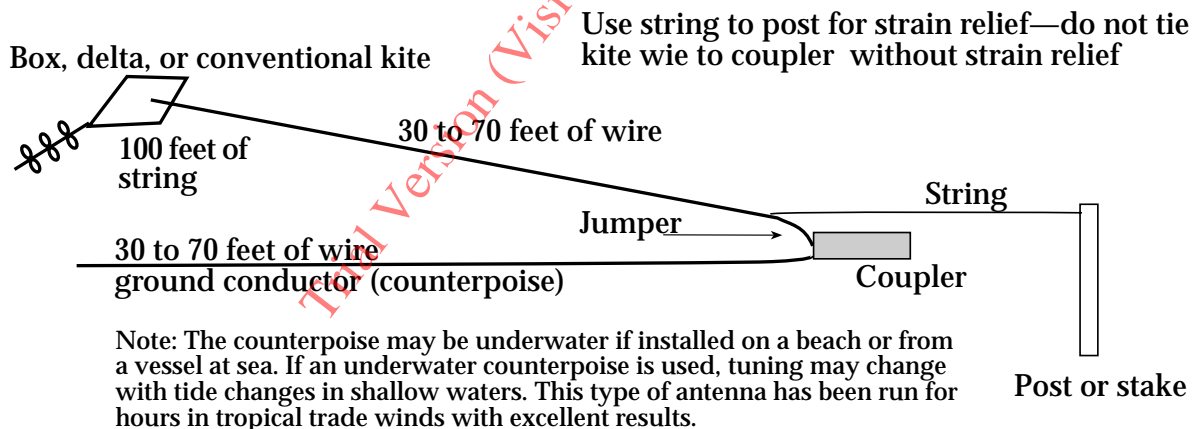

This is our recommended antenna to be carried aboard all types of vessels. This is because when a wind strong enough to damage a boat occurs, it is easy to fly a kite and this may lift fifty to one hundred feet of antenna wire. For good emergency communications, you will only need 30-70 feet of antenna and a strongly built (Mylar or nylon) kite.

SGC SMARTUNER MANUAL 26

Remember that when a mast comes down, you have easy access to the high voltage feed line which may be secured to a kite antenna. Offshore power boats can use this antenna as well, since 10-20 knot winds are almost always available when underway at sea.

4.10.2 Tactical Installations

Over the course of nearly 25 years of HF communications, SGC equipment has been used everywhere from camel back in the desert to Antarctic expeditions. Along the way we have collected a number of tips to get maximum system performance from your radio system when you are operating in a tactical or disaster situation. These tips, by the way, also apply when you go camping or are involved in amateur radio Field Day activities:

Tactical Antenna Supports. Except for a barren desert, just about all landscapes have structures (natural and man made) that can be used for antenna supports. All it usually takes is several hundred feet of rope and some creativity. Here are some examples to consider. If you wonder which structure would work best remember the one with the greatest height and greatest distance from grounded metal will generally give the best performance.

Natural rock formations such as cliffs and bluffs.

Tall trees.

Water towers.

Church spires and minarets of mosques.

Rooftops of buildings – strung between.

Sign posts such as for banks and gasoline stations.

Telephone (*not power*) poles. There's no power line noise on telephone poles.

Railroad trestles

Highway structures: signs, overpasses, and bridges.

Flag poles at public buildings, schools, and hospitals.

Tactical Grounds And Counterpoises. Just as antenna opportunities abound, so do ground and counterpoise opportunities to the professional eye. Some of our favorite examples which correspond to the antennas above include:

Cross country water and petroleum transmission pipes (e.g., as it passes under a bluff)

Long steel cables along a mountain highway (e.g., one with nearby trees)

Chain link fencing (e.g., around a water tower)

SGC SMARTUNER MANUAL 27

- Metal lawn sprinkler piping (e.g., in a church yard)
- Fire department standpipes (required in most big city building codes)
- Underground metal petroleum storage tanks (e.g., at a gasoline station)
- Metal fencing of any type (e.g., a barbed wire fence along a pasture or under telephone pole)
- One hundred feet of wire thrown into a river or sea (e.g., under a trestle)
- Metal drain culverts (e.g., along a highway)
- Four to five cars parked with their metal bumpers touching
- A sheet metal roof (e.g., hospital or public building)

As you can see from this list, there are an almost limitless number of options available to install a high performance antenna system with only a small amount of wire and a SMARTUNER.

4.11 FIVE GOLDEN RULES OF HF INSTALLATION

These rules apply to all types of stations, including base, mobile, airborne and marine. They are very important for planning and installing your HF system if you want to achieve good communications.

1. Install transceiver as close to your operation site and to the power supply system as possible (whether it is an external power supply or battery system).
2. The antenna must be installed in an open space and as far as possible from your operating point. As an example, on a sailboat, use the backstay as the antenna, since it is the farthest point away from the rest of the vessel.
3. The antenna coupler must be installed at the base of the antenna.
4. Always create your own ground with radial wire or copper straps. They are the only ones that will guarantee a solid and proper ground system.
5. All cables - power supply, control or coaxial - must always be as short as possible and/or necessary. Any excess cable should be shortened to the proper length - never coiled.

Following these rules will minimize marginal installations and problem sources such as RF feedback in the radio, power supply or cables and "hot" or RF burning microphones. If all 5 above points are followed during the design and installation of your HF system, the operator can expect top performance.

SGC SMARTUNER MANUAL 28

5.0 General Notes on Antennas and Couplers

1. The longer the antenna, the generally better the antenna performance. By doubling the length of the antenna, an improvement of 3 to 6 dB can be expected in your radiation or receiving characteristics. This is the equivalent of transmitting with 400 watts, when actually you are using only 100 watts.
2. A ground for end-fed antennas can be effectively created by running radial wires from the coupler point and burying them in the ground. We recommend for a good ground that 12 radials should be used and they be about 1/3 longer than the antenna length. The number of radials can be reduced; however, you need at least one. Efficiency pattern and radiation will decrease in proportion.
3. Antennas will always perform better if the wire is of a large gauge. Never use anything less than gauge 16. If gauge 6 is used, an improvement of 6 dB can be expected over the 16 gauge. The radial ground wire should be at least the same size as of the antenna wire.
4. The SMARTUNER coupler can handle antennas beyond the specified minimum range of 8 to 80 feet and should be extended as much as possible. In some cases, the antenna can be 300 feet or longer. In this situation, you may find some tuning holes. The antenna can be made a little shorter or longer to overcome the tuning hole on the frequency band you may have wanted to use.
5. Always install the antenna system as far away as possible from any electrical or industrial noise source. Electrical appliance, electric motor, or fluorescent lighting noise may cover up weak or even strong signals.
6. A remarkable antenna coupler, the SMARTUNER will tune practically any antenna—good or bad. Keep in mind that it is not the coupler that will radiate the RF energy, it is the antenna. Therefore, use only good size wire and long antennas.
7. Never use a feed line or coaxial cable at the output of the antenna coupler. The coupler functions to couple the radio to the antenna, not to act as a mid point connector. Because the antenna system starts at the output of the coupler, the lead end from the coupler to the hypothetical antenna is part of the antenna system. Avoid having the lead end wire touch any other metal structure: it will capacitively short your antenna to ground.
8. The backstay of your mast is the *only* viable antenna on a sailboat. The SMARTUNER coupler is specifically designed to be used for such applications.
9. For vehicular installation, do not use any inexpensive CB antennas and/or mounts. These antennas will not perform well from 1.8 to 10 MHz even though

SGC SMARTUNER MANUAL 29

the coupler will load and tune the antenna whip. A high voltage of 15,000 to 30,000 volts RF will be applied to the antenna depending on the RF power level and frequency. The inexpensive ball mounts for CB antennas are not designed for so stringent a purpose. We recommend the use of an antenna system such as the SG-303: it was specifically designed for such extreme applications.

5.1 Steps to Antenna Installation

System installation is a three-part process covering the following steps:

1. Selection and installation of the antenna
2. Mounting the antenna coupler
3. Connecting the appropriate interface cables between the coupler and the transceiver

This manual section will discuss the three steps mentioned above in detail and will provide sufficient information to enable the user to confidently install a complete system properly.

The antenna system is a key part of the communication system. For satisfactory operation the system must be carefully selected and then installed correctly. The unbalanced antennas used with the automatic antenna coupler use the ground (counterpoise) as half of the antenna system. The ground forms an “image” antenna and is a critical part of the system. It is essential to consider both the ground and the antenna when designing the system installation.

5.2 Antenna Location

The figures in Section 4.0 illustrate several different antenna installations. The following points should be carefully considered when designing the antenna system.

- a) The antenna should be located in a position free of obstructions, particularly in the desired direction of communication.
- b) The antenna should be kept as far away as possible from buildings, trees, and vegetation. If metallic masts or supports are used, arrange the insulators so that the antenna is spaced at least 2 meters from the mast.
- c) Remember that the radiating part of the antenna starts at the coupler. The location of the bottom portion of the antenna is important.
- d) Vertical antennas have an omni-directional radiation pattern, providing equal performance in all directions.

SGC SMARTUNER MANUAL 30

- e) Horizontal wire antennas have maximum radiation broadside to the antenna when the frequency is less than $1/4$ wavelength. As the frequency increases beyond $1/4$ wavelength, lobes will appear in the radiation pattern with the principal lobes becoming closer to the plane of the antenna as the length increases. At all times, radiation will be minimal at the end of the antenna; therefore, it should be located so that the ends point in directions where communications are not required.
- f) The V antenna construction minimizes the directivity of the horizontal antenna and is recommended for all around coverage. In addition, the V antenna is a compromise between vertical and horizontal polarization and will give good results for communications with land or marine mobiles using vertical whip antennas.
- g) High voltages (sometimes exceeding 30,000v RF) are present on the antenna. All parts of the antenna and coupler must be located or protected so that there is no possibility of accidental contact.
- h) Do not locate the antenna close to other antenna systems.
- i) Make sure that the antenna is rigidly supported. The antenna will de-tune if it sags or sways.
- j) The connection from the coupler to the ground must be a small percentage of the total length of the antenna. Do not let the length of the ground strap exceed 1.5 meters. Use heavy gauge wire or strap for ground connection.
- k) Whip antennas should be connected with the minimum length of wire. (Do not exceed 0.6 meters).
- l) Do not locate the coupler farther from the transceiver than necessary. If the distance exceeds 10 meters (30 feet), we recommend you use low loss coaxial cable, such as RG-8 or Belden type 9943.

5.3 Ground Systems—General

The ground system (also called a counterpoise) is a key part of the overall antenna system and is the primary cause of poor performance and the difficulty of adjusting the coupler. A good ground is essential.

5.3.1 Vehicle Grounds

Connect the coupler directly to the frame of the vehicle. Ensure that a heavy strap is used from the coupler ground lug and that the connections are cleared of all paint and dirt so that the shiny metal is exposed. SGC always recommends that two grounding bolts with star washers be used to ensure no ground resistance is encountered. Make

SGC SMARTUNER MANUAL 31

sure that the grounding point is not insulated from other parts of the vehicle by non-metallic couplings, bushings, fiberglass panels, etc. Modern vehicle assembly techniques that use spot welding may not always adequately connect various body parts. Use an ohmmeter and insure your vehicle is electrically bonded.

Another area to watch is trunk lids and hoods. Because many body parts are dip painted, they may float above the RF ground when assembled. Use of short heavy braid to insure all doors and hatches are grounded is good installation practice. Although this is tedious work, the benefit is that once completed you will have a much superior radiated signal and lower noise floor on receive.

5.3.2 Marine Grounds

A metal-hulled vessel in salt water provides an almost ideal ground. The coupler should be connected directly to the hull using the shortest possible ground strap or 2- to 3-inch wide 2 mil copper foil. Make sure that the contact point is free from paint and dirt. Ensure a good contact area for minimum resistance.

Wooden and fiberglass hulled vessels present more of a grounding problem. It is normally necessary to bond all large metallic parts such as the stove, fuel tanks, engine, and propeller shaft; sometimes an external grounding plate should be connected to the hull. The bonding and grounding plate should be chosen with consideration for the problems of electrolysis. Severe damage may result if dissimilar metals are connected together.

Our experience is that sacrificial zincs, which double as radio grounds, may help, but are not by themselves a complete solution. If you use one (or more) of these devices, remember to provide for a large physical counterpoise in addition.

In a sailboat installation, we generally place the SMARTUNER in the aft lazaret and then run at least three runs of foil forward. One runs up the port chine, just below the waterline, another up the starboard chine below the waterline, and the third up the center of the vessel.

The center foil is generally connected to the rudder post, transmission, engine, and keel bolts. The chine foils are attached to through hulls, the stove, tankage and so forth. The idea is to get as much metal inside the vessel connected as possible. Metal toe rails and life lines work well as do keel coolers on motorized craft.

Here is a neat trick for attaching foil to keel bolts. When a large keel bolt is exposed, drill into the keel bolt and tap the hole for a suitable stainless steel machine screw. Attach with suitable copper washers for a solid electrical connection.

Although it is not mandatory that ground foil be glued into place, we consider it a good idea to keep the space below decks neat and orderly under all conditions.

SGC SMARTUNER MANUAL 32

If you are using a backstay antenna, try to visualize your ground as you look down from the top of the mast. Ask yourself if you see 100 square feet of metal below you. The closer to this figure you can get, the better your radiated signal will be. What you are trying to do is make a large capacitor to the seawater. Consider the salt water of the sea to be one plate of a capacitor, the ground system the other, and the hull to be the dielectric.

On marine installations, you should also be aware of potential noise sources that may need to be bypassed to ground. We have encountered just about every source of noise imaginable in vessel installations. The best time to track down annoying noise sources is when you are laying in a ground system. Not only will you get much better voice communications, but Weatherfax, Navtex, and Loran reception will improve as well if they are also tied into the ground system.

Particular attention should be paid to any device that uses an electric motor. This means to turn on the water pressure pump, bilge pump, hot water forced air heater fans, refrigeration, and auto pilot motors. A few small capacitors to ground (.01 microfarads at 100 VDC) can resolve many issues. Bypassing of the vessel's alternator is also a good idea.

5.3.3 Base Station Grounds

In areas of high ground conductivity, an effective ground can be made through a grounding rod. The rod should be approximately 3 meters in length and should be installed as close as possible to the coupler. It may be necessary to use several ground rods bonded together to improve the ground contact. Water pipes are sometimes recommended as grounds and may be used provided plastic pipe is not buried as part of the system and the following conditions are met:

- a) The water pipe is close to the coupler.
- b) The water pipe enters the ground close to the coupler bonding point.
- c) There are no joints or couplings in the pipe that will increase the resistance path to ground.
- d) The water pipe enters soil with good conductivity.
- e) A low resistance contact is made to the water pipe.

Earth requiring a counterpoise. Frequently the ground conductivity will not suffice to provide satisfactory operation of the coupler—almost certainly the case with well drained sandy, rocky, or loamy soils. Therefore, a counterpoise (artificial ground) must be used as the ground system.

Rooftop installation requiring a counterpoise. In a rooftop installation where there is no existing ground plane, the ideal ground would be a conducting surface extending several wavelengths in all directions around the antenna. On a rooftop, this situation

SGC SMARTUNER MANUAL 33

may be approximated by placing a screen of chicken mesh, copper hardware cloth, or similar material over the roof of the building. More frequently, a counterpoise system of radial wires must be used. SGC recommends the use of at least 8 to 12 radials bonded together in the center. If the antenna is at ground level, the radials should be buried a few inches below the surface.

5.4 Corrosion

Ground connections are subject to corrosion and oxidation. All joints must be clean and the hardware adequately tightened. Joints should be well soldered wherever possible. The joints may be protected by an application of silicon grease and, under severe conditions, covered with electrical tape and waterproof varnish or a durable brand of silicon caulking.

If you are mounting your SMARTUNER on a vessel where a lot of salt spray is encountered, it is a good idea to put the wire connections that are exposed to weather on your six-month periodic maintenance plan. Then, every six months, you will be reminded to undo each of the connections, clean, retighten, and reseal.

Use jumpers around metal backstay triangles on split backstay antennas. Corrosion may cause up to several hundred ohms of resistance to occur even though you may think that a metal-to-metal connection would be a good one.

5.5 Antenna Coupler Mounting

The coupler is mounted using the proper mounting ears on the case. Choose a location immediately adjacent to the antenna feed point. In trunk-mounted mobile installations, locate the coupler so that the antenna insulator is within a few centimeters of the antenna exit hole. Note also that the antenna lead must pass through an insulated bushing. High voltage connecting cable must be used. (RG-8U cable with solid insulation may be used if the outer shielding is removed). When the coupler is installed on the outside, or on the deck, we recommend a protective housing.

5.6 Antenna Connection

The antenna lead is connected to the high voltage insulator. During operation, use two wrenches when tightening the nut to prevent the stud rotating. A potential of several thousand volts may be present at the antenna terminal and adequate protection must be made against accidental contact. It is also necessary that the antenna be spaced at least 3 centimeters from the conducting surface. Sharp points in the lead-in wire should be avoided to prevent corona discharges.

6.0 Installation Procedures

SGC Inc. SGC Building, 13737 S.E. 26th St. Bellevue, WA. 98005 USA

SGC SMARTUNER MANUAL 34

The following diagrams will assist you with installing the SMARTUNER with SGC equipment.

6.1 Installation with SG-2000

The SG-2000 is shipped with all necessary connectors for installation of a SMARTUNER™ and for installation of peripherals by means of the audio input/output jack on the rear panel. You will see the connectors when you remove the Philips head screws that hold the protective sheet metal cover over the rear panel connectors.

From left to right, these jacks provide the following:

- J-502** SMARTUNER connections
- J-301** Aux. Audio input/output and PTT line
- J-503** Remote control head or multiple head junction box
- J-504** Remote control head or multiple head junction box (Head mounted on radio is normally connected here.)
- Ext. SPK** External Speaker
- Oven** Turns oven On-Off (Shipped with oven ON as default)

SG-2000 to Smartuner Coupler Connections

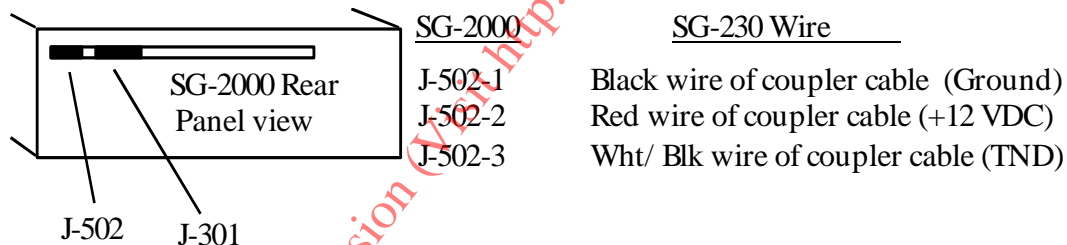

6.2 INSTALLATION ON ALL RADIOS

The SMARTUNER requires only a source of +12 VDC (optional: +24 VDC), an RF transmission line (RG-58/U up to 30 ft., RG-8 OR RG-213/U if over 30 ft.), plus suitable ground and antenna systems. No band switch information, low power tuning, or handshake is required, since the coupler tunes on RF voice or carrier. Power consumption is normally less than 1 amp, allowing for use of small gauge wire. The PCB is fully protected against power reversal. The output for a remote mounted tune indicator, if desired, is strictly optional.

When installing your SMARTUNER, remember to allow for the power to be disconnected from the battery during periods when equipment is not being used. This will prevent draining the battery unnecessarily.

SGC Inc. SGC Building, 13737 S.E. 26th St. Bellevue, WA. 98005 USA

SGC SMARTUNER MANUAL 35

6.3 Smartlock Installation

The SmartLock is an optional accessory with the SMARTUNER. This gives the user additional control over the coupler. It is not required for normal operation of the coupler and does not need to be installed. It allows the coupler settings to be held in place so no tuning or retuning will occur, and has an LED indicator which will light when the coupler is tuned, and provides a manual reset of the coupler without turning the power off and on.

Connections:

SG-230	Smartlock
Red wire (+12VDC)	red wire
Black wire (Ground)	black wire
White/Black wire (TND)	green
White/Red (Reset/Lock)	white

We recommend soldering the wires together and insulating the exposed wires with heat shrink or electrical tape; however, other methods may suffice as long as the connections are firm and there is no exposed wiring. A schematic drawing is provided as an aid to understanding the operation of the SmartLock.

Smartlock Schematic Diagram

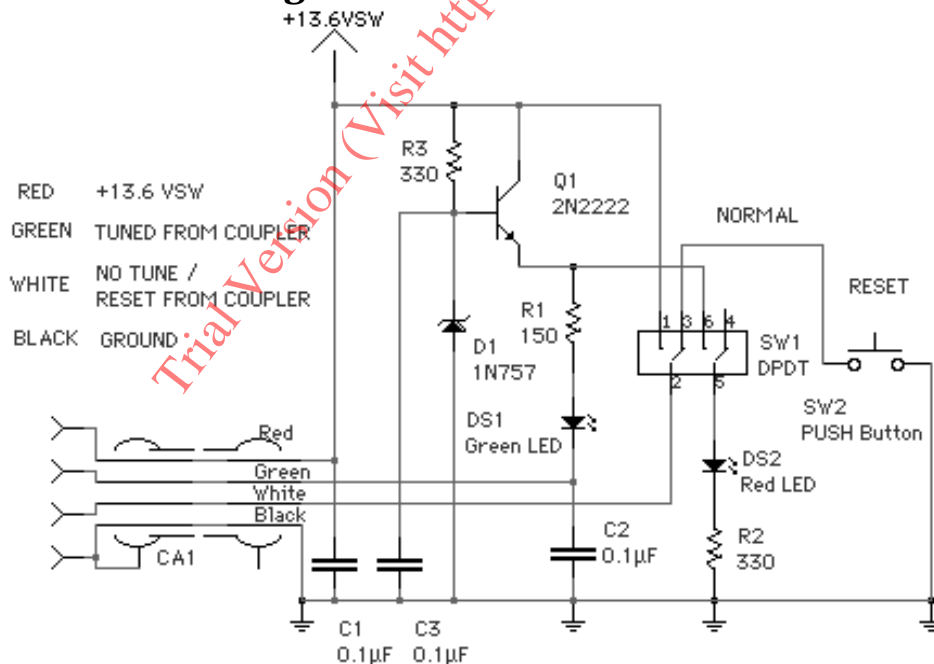

6.4 Weatherdeck Mounting

SGC Inc. SGC Building, 13737 S.E. 26th St. Bellevue, WA. 98005 USA

© Nov2000 SGC, Inc.

P.O. Box 3526, 98009 Fax: 425-746-6384 Tel: 425 746-6310
E-Mail: sgc@sgcworld.com Web Site: www.sgcworld.com

SGC SMARTUNER MANUAL 36

Weatherdeck mounting can be used. Years of experience have shown that inside mounting or even splash-proof mounting is preferred, particularly in cold, damp environments. In tropical use, shielding from direct sunlight is desirable.

The base of the antenna should be connected to the high voltage feed-through insulator on the housing. Note that this insulator is not designed to support heavy mechanical loads. If such loading is encountered, use a strain insulator.

The ground system should be connected to the 1/4-inch stainless steel stud protruding from the bottom of the housing. Connection to the ground system is extremely important to a successful installation. Ground runs of over a few inches should be made from 4-inch-wide copper strap or larger. The actual ground system should be as good as possible, as the ground is an integral part of the antenna system. See section 5.3 on grounding. However, couplers in general require the antenna parameters to be within the range of the tuning parameters or the coupler will not find a satisfactory match. The computer in the SMARTUNER cannot second-guess the installer.

A proper antenna/ground installation is of great importance: regardless of whether your station is a base station, marine, or land mobile.

6.5 Electrical Checkout

After the SMARTUNER antenna coupler has been installed, the SSB transmitter should be adjusted to the *highest* frequency desired, and a directional watt meter (e.g., Bird Model 43) should be inserted into the transmission line. The transmitter should then be powered. The SMARTUNER will begin to tune when RF power is applied, and you will hear a “clattering” of PC-mounted relays. If the antenna length and ground parameters are within range, the relay noises will stop when just a few words are spoken, and the reflected power on the watt meter would indicate a value of better than 2:1 VSWR. The “TUNED” LED, which is mounted on the PC board, will light, and if there is a remote “TUNED” indicator, it will also light.

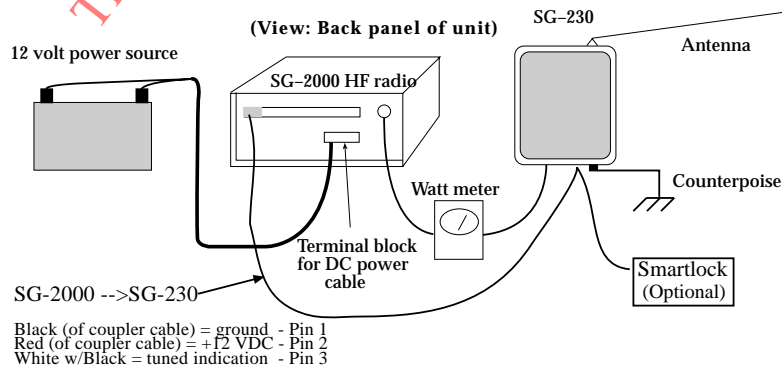

SGC Inc. SGC Building, 13737 S.E. 26th St. Bellevue, WA. 98005 USA

© Nov2000 SGC, Inc.

P.O. Box 3526, 98009 Fax: 425-746-6384 Tel: 425 746-6310
 E-Mail: sgc@sgcworld.com Web Site: www.sgcworld.com

SGC SMARTUNER MANUAL 37

Next, the SSB transmitter should be adjusted to the *lowest* desired frequency, and the test as outlined above should be repeated. The SMARTUNER should immediately sense the mismatch and switch to the tune mode to retune the antenna system. Since the algorithm must search through more possible values of L and C to find an appropriate combination at the lower frequencies, the tune cycle may take longer. A few spoken words should achieve an "all tuned" indication. The SMARTUNER installation and tune-up are considered complete if the above tests have been successfully performed.

The SMARTUNER will probably not be supplied from SGC with memory data appropriate to your installation, and the memory feature may not seem impressive at first. Allow the SMARTUNER to "learn" your antenna's requirements by proceeding from frequency to frequency and allowing the normal tune-up to occur. As the SMARTUNER computer memorizes more and more frequencies, you should then be able to return to a previously tuned frequency and find that the coupler immediately responds "ALL TUNED," even before the first word is completed.

The memory system is capable of storing hundreds of individual frequency/relay combinations, mostly in the lower operating frequencies, providing better memory resolution at lower frequencies where antenna systems are inherently narrow band. Usually, only one or two memory positions are needed to provide satisfactory coverage at higher frequency bands.

6.6 Do-It-Yourself Light-Bulb Dummy Load

Any time that a transmitter is used, it must be outputting into a load. A load is anything that the output power can be pumped into. If the transmitter is operated without any sort of load connected, the final amplifier stage could become severely damaged. The problem is that you should never test a transmitter on the air for the first time, if you are unsure about how to operate it, and if you are unsure whether it is working properly. You could create harmful interference to other stations.

To test transmitters without actually operating into an antenna, dummy loads were created. A dummy load is a load that will dissipate the energy from the transmitter instead of emanating it into the ionosphere. Nearly all commercial dummy loads are large oil-filled cans. These dummy loads change the transmitted energy into heat, which is absorbed by the oil. Because different transmitters output different amounts of power, different sizes of dummy loads must be used. Dummy loads for typical amateur powers (under 500 watts) are relatively inexpensive and are readily available.

Unfortunately, when you use a can-type dummy load, you can't see "what's happening" with your transmitter. In this case, you can use a light-bulb dummy load to test your transmitter. Here, the light bulb is directly connected to the output of the transmitter and it dissipates the RF energy as light. The light bulb dummy load is more useful than

SGC SMARTUNER MANUAL 38

the oil-can type because you can guess how much power is being output, you can see the voice modulate the SSB (the light will flicker with your voice peaks), and you can tune the transmitter for maximum output (if the transmitter is an older model that requires tuning).

Before building or using the light-bulb dummy load, remember that these models typically don't dissipate the transmitter's output as well as an oil-can dummy load. The result is that RF will "leak" out; I have heard a few stories of amateurs who were heard around town while operating their transmitters into a light-bulb dummy load. If you use this system, make sure that you test the equipment on a clear, harmless frequency (NEVER test with the transmitter set on an emergency frequency, such as 2182 KHz).

SGC recommends that you build the light-bulb dummy load with the following parts (although I have made one with an old light fixture and a makeshift version with just alligator clip leads and a light bulb):

- * AC socket to cable with a PL-259 connector (for transceiver)
- * AC socket to cable with alligator clips (needed with coupler)
- * Light bulb to AC adapter
- * 75 to 125 watt light bulb, 120 to 220 VAC
- * 100 watt radio transceiver
- * SG-230 coupler (optional)

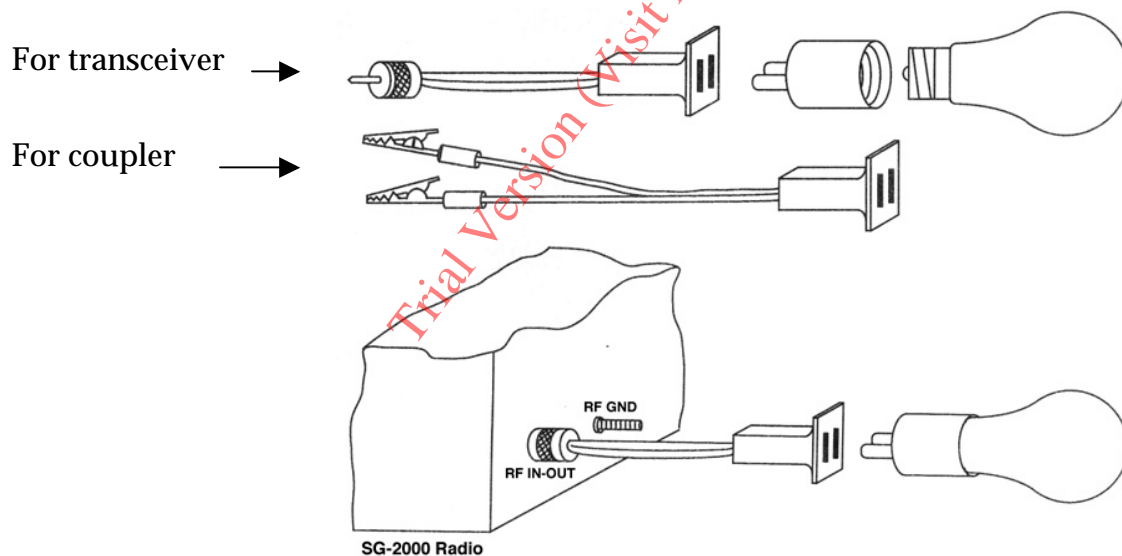

SGC SMARTUNER MANUAL 39

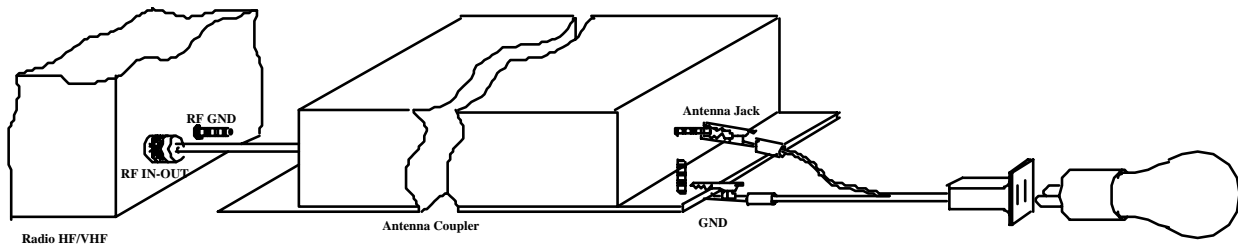

RADIO TEST PROCEDURE

1. Connect the transceiver light bulb load to the radio RF in/out jack.
2. Turn on the radio and set the CW mode.
3. Key the PTT switch on the microphone and look at the light bulb. If the light bulb load is connected and the radio is transmitting, the light should turn on.
4. Set the power to LO.
5. Set the radio to SSB mode.
6. Key the PTT switch on the microphone and talk into the microphone. Notice that the light turns on when you talk.

COUPLER TEST PROCEDURE

1. Connect the coupler to the radio.
2. Connect the coupler light bulb load to the SG-230 antenna jack.
3. Turn on the radio and the SG-230.
4. Set the radio to the CW mode.
5. Key the PTT switch on the microphone and look at the light bulb. The light should turn on if the coupler has completed its tuning cycle and if the radio is transmitting.
6. For further testing, follow steps 5-6 of the radio test procedure.

Note: The light bulb might not turn on immediately if the coupler has not yet been tuned for the frequency of the transmitter. The output power (light-bulb brightness) is greatest when the coupler is properly tuned.

This test will ensure that the radio and coupler are working properly.

7.0 Coupler Configuration

Schematic Q30102000, sheet 4 is the schematic diagram of the two basic coupler networks. Note that the L network as viewed from the generator, may be configured as either "C in" or "C out," whichever is required by the load. In either case, the end of the network containing the shunt C element will be the **higher** impedance end of the network.

7.1 Schematic Diagrams

Schematic Q30102000, sheets 1 thru 6, are schematic diagrams of antenna coupler.

Connections to Smartuner

SGC Inc. SGC Building, 13737 S.E. 26th St. Bellevue, WA. 98005 USA

P.O. Box 3526, 98009 Fax: 425-746-6384 Tel: 425 746-6310

E-Mail: sgc@sgcworld.com Web Site: www.sgcworld.com

SGC SMARTUNER MANUAL 40

RF Input	ST-1
RF GND Input	ST-1
13.6 (24) VDC	ST-7
DC GND	ST-8
RF Output	ST-9
RF GND Output	ST-3, ST-4
TND	ST-6
Reset/Hold	ST-5

The TND line **cannot** be connected to the SG-2000 and SmartLock units simultaneously.

7.2 Tuning Process

An array of detector devices in the SMARTUNER monitor the antenna system impedance, reactance signal, and the VSWR load when RF power is applied to the unit. The coupler also monitors forward power, since the control computer requires an indication of both forward and reflected power in order to allow tuning to proceed. The computer uses the forward power detector as a check to ensure that the measurements made are applied RF and are not spurious levels from the data conversion system. The SMARTUNER will proceed to tune *only* when enough forward power is present to confirm this check.

After RF is applied to the coupler array, it then passes through the detector system. The detector system consists of six capacitors in shunt on the input arm of network, eight inductors in the series arm, and five more capacitors in shunt on output arm, all arranged in binary increments. Relays are provided in conjunction with each lumped constant and allow removal or entry as desired. A network having 64 values on input shunt C, 32 values of output shunt C, and up to 256 values of series L is possible with the manipulation of these 26 relays.

7.3 Impedance Detector

RF transformers T1 and T2 drive the impedance bridge that is balanced at 50 ohms. T2 samples the line current and thus D5 outputs a negative DC level proportional to line current. A tertiary winding on transformer T1 provides a line voltage sample to D10 that provides a positive voltage proportional to line voltage. R49 and R50 act as a summing network for the current and voltage signals, with ratios chosen, such that at 50 ohms, the summed signals result in a balanced or zero voltage condition.

If the line impedance goes to **high**, the signal from the *voltage* sensor will be relatively higher than the *current* sensor, which will result in a net **positive** output voltage from the summing

SGC SMARTUNER MANUAL 41

network. Similarly, a **low** line impedance will result in more output from the *current* sensor, resulting in a net **negative** output voltage from the summing network which is shifted to a 0 to 5v range, then fed to processor's A to D converter ports, and used within microcontroller.

7.4 VSWR Detector

A directional coupler is made up of a current transformer T3 and a voltage transformer T1, in conjunction with termination resistors R31 and R32. The coupler is inserted in the 50-ohm transmission line between the input connector and the tuning network. The **forward** power is measured across termination R32 and **reflected** power is measured across termination R31. Diode D4 generates a positive DC voltage proportional to **forward** power and D9 generates a positive DC voltage proportional to **reflected** power. The **forward** DC output is fed to a voltage divider consisting of R58 and R48. These voltages are input to the RF power detector and to an A to D converter port of the processor. The **reflected** DC output passes through a voltage divider consisting of R53 and R54, and then it also goes to an A to D converter port of the processor.

7.5 Phase Detector

A phase detector is formed by T2, A1, and their associated components. This detector indicates the state of any reactance associated with the antenna coupler as noted from the generator. A line current sample is compared in phase with a voltage sample in a double balanced mixer. The output of the phase detector A1 is shifted to a 0 to 5v range, then fed to the processor's A to D converter ports and used within the microcontroller.

7.6 Central Processing Unit (CPU)

A tune-up algorithm, which is contained in the memory of the microprocessor, actually implements the antenna matching. It is designed around the MC 68HC711E9 CPU which features a versatile instruction set, RAM, and EEPROM (memory which is saved after the coupler is turned off). The antenna coupler relays are controlled by latches U7, U8, and U9, which receive serial data input directly from the CPU.

During operation, data is transferred into the CPU from the A to D ports and Input Capture port (measures RF frequency). Basically, the program monitors the status of the input sensors and—starting from a preset condition—uses a built-in algorithm to achieve a tuned condition. When the tuning algorithm is complete, the CPU saves the settings in its EEPROM, which is addressed by the applied RF frequency.

This non-volatile memory table is the basis of the exclusive *learning* feature of the SMARTUNER. After it has stored and latched the network status, the CPU waits for RF to cease transmitting and returns to the **Stop** mode. When RF is retransmitted, the first step in the tuning algorithm is to measure the frequency of the signal passing through the coupler. From the frequency data, the computer then searches its EEPROM for previously stored data. If

SGC SMARTUNER MANUAL 42

data is found, it is tested for validity, and the required “end of tune” conditions will be sensed by the RF sensors. Then the data will be latched in place, and the CPU will again wait for RF to cease transmitting and return to the **Stop** mode. This process takes about 20 milliseconds, which is the same length of time that is required to close the network relays.

7.7 Initialization

The microcomputer is usually in the **Stop** mode and requires an interrupt signal (XIRQ) to start program implementation. The IRQ is obtained from the RF detector circuitry. This line goes into the XIRQ pin of the CPU and will wake the CPU from the **Stop** mode.

7.8 Bypass Operation, Jumpers

The SMARTUNER may be bypassed for broadband (untuned antenna) scanning listening. All you need to do is press the reset button of the SmartLock (if installed) or turn power to the coupler off and on. When the coupler comes back on, the tuning elements remain out of the circuit until the Smartuner is activated by a *transmitted* signal.

If broadband operation is required during receive for scan operation, jumper JP1 may be set to the **Yes** position. This will drop the tuning elements out of the circuit on receive only. Jumper JP1 is located adjacent to U1. If you open your SMARTUNER to access this jumper, please use caution to ensure that the waterproof seal is carefully placed prior to refitting the coupler cover.

Setting JP1 to the **Yes** position is recommended if you are using a radio for split band communications, for scanning selective calling protocols, or for Automatic Link Establishment (ALE). The default is: Tuning Out In Rcv: [no].

Jumper JP2 bypasses the coupler's memories. This means that each time the coupler is used on a different frequency, it will retune rather than use previously stored information. The default is: Tune From Memory: [yes].

SMARTUNER MicroTune™ Software

8.0 Tuning Processes and Options

The SMARTUNER MicroTune™ Software is unique software that allows precise tuning of the digitally controlled **pi** and **L** network to tune a wide variety of antennas.

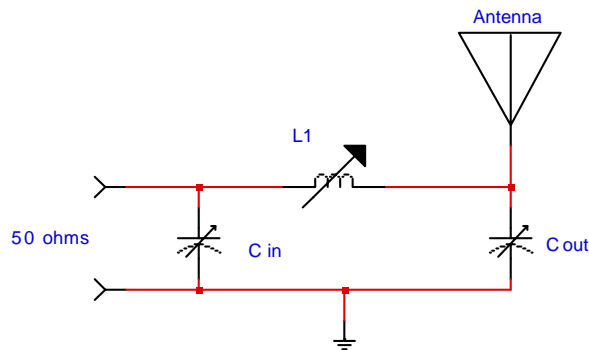

The versatile MicroTune™ software offers its user these special functions:

1. The coupler is activated whenever forward power is present.
2. In addition to sampling VSWR to determine if the coupler should retune, frequency comparison is employed. This causes the coupler to tune whenever the transmit frequency changes independent of the VSWR reading.
3. Extensive tuning paths are used to test different antenna situations. The initial tuning of a new frequency (or switched antenna) may require a few seconds. Any further tuning is accomplished in a matter of milliseconds if jumper JP2 (Tune From Memory) is in its default position.
4. Facilities and algorithms are used which enable accurate tuning at the low end of the frequency band—even on shorter antennas than previously possible.
5. The BITE (Built-In-Test-Equipment) Indicator Tune LED includes a safety feature that alerts the operator to a mismatched condition, with blinking indicators, when proper tuning conditions have not been met. In this situation, the software will “time out” within 10 seconds unless a new frequency is sensed, which will cause an immediate time out, and the coupler will attempt to match the new frequency.

The microprocessor of the coupler “wakes up” every time the coupler has forward power. However, re-tuning takes place only if the frequency has changed or the VSWR exceeds 2:1.

8.1 Program Description

When DC power is applied, the computer initializes the processor registers in accordance with the hardware. All tuning elements are then removed and the 'tune' indicators are turned off. At this time the computer reverts to a "sleep" mode awaiting RF power.

SGC SMARTUNER MANUAL 44

Detecting no forward power. When RF power is detected, the CPU will perform a test to verify forward power is present. If no forward power is detected, the computer will revert to the **Stop** mode. If forward power is detected, the CPU next checks the **Hold** signal from the SmartLock. If the user has switched on the Tuned Lock function of the SmartLock, the **Hold** line will be low and the CPU will not proceed with the tuning algorithm. It will wait for forward power to be shut off and return to **Stop** mode.

Detecting forward power. Once forward power is detected and the SmartLock is switched to Normal, the current coupler settings are sent to the relays. Next, the VSWR is checked and the frequency is measured. If the VSWR is greater than 2:1 or a difference in frequency is detected, the program branches to the re-tune program. If it is determined that the VSWR is less than 2:1 and the frequency has not changed, the computer returns to the **Stop** mode.

Re-tuning. Once it is determined that re-tuning is necessary, a test is made to see if JP2 is set to tune from memory. If the result is re-tuning from memory, settings are recalled from the EEPROM based on the frequency measured.

The recalled data is then tested for validity. If the data proves invalid, it is bypassed and re-tuning is performed. If the data recalled proves valid, the data is sent to the relays and the VSWR is checked. If the VSWR is less than 2:1, the program branches to the "OK Tuned" section of the program. If the VSWR is found to be greater than 2:1, the program branches to the "re-tune" program.

Selecting tuning path. Several tests are made to determine which tuning algorithm or path should be used to tune the coupler. These tests are based on frequency, antenna input impedance, antenna phase, and VSWR. Numerous sub-routines are executed repeatedly, depending on the status of the criteria mentioned above, in order to achieve proper tuning.

Signaling "no-tune." Should the initial primary tuning sequence prove unsuccessful, secondary algorithms are attempted until all possible routines have been exhausted. If, after the secondary attempts, the coupler still cannot achieve a proper VSWR, the program branches to a "no-tune" program. Here, the LEDs and remote tune indicator will blink on and off for about 10 seconds to tell the user a proper VSWR could not be found. After the indicators stop blinking, the program waits for forward power to cease (if it has not ceased already) and returns to stop mode. At this point the user should try several other frequencies. If the "no-tune" condition persists, check the installation of the antenna, coupler, radio, and ground system for possible problems.

Signaling "OK tune." If the coupler achieves a good VSWR during the tuning sequence, the program branches to the "OK Tune" section of the code. Here, the tune indicators are engaged. A test is then made to check if JP2 is set to tune from memory. If

SGC SMARTUNER MANUAL 45

so, the frequency is measured and the tuning elements used are saved in memory coupled with a verification code.

Once saved, a test is made on JP1 to check if the duplex mode has been selected. If so, the transmit tuning elements remain in circuit until the receive mode is verified. At this time, all tuning elements are removed.

The frequency is then saved for future comparison and the CPU reverts back to the STOP mode.

8.2 Tuning Paths

As mentioned previously, various tests are executed to determine the most logical tuning sequence to be performed. Dependent on the test results, additional tests and appropriate sub-routines are executed throughout the tuning process. Following are examples of the activity that occurs when the coupler must be matched to a frequency that requires a slightly longer or shorter antenna:

8.2.1 Antenna Too Short

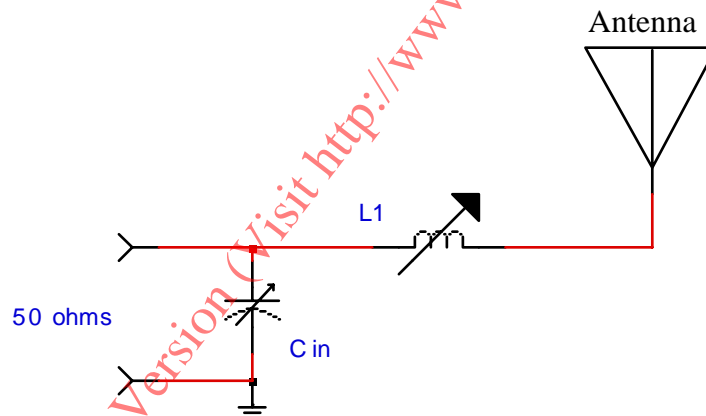

Once the coupler has verified RF power, the tuning sequence proceeds as follows:

1. Series inductance is added until the phase is deemed as being inductive. At this point it is normal for the input impedance to be low.
2. Input capacitance is added until the antenna is no longer inductive.
3. The program will continue to increment the series inductance in $.25 \mu\text{H}$ steps—each time normalizing the input impedance with input capacitance—until a low VSWR is measured of less than 2:1. This process will continue until the VSWR has climbed back to higher than 2:1 or the impedance has become high.
4. The settings that gave the lowest VSWR have been kept in memory and are now recalled to verify it is a low VSWR

SGC SMARTUNER MANUAL 46

- At this point the tune indicators are engaged. The current relay data is saved if JP2 is set to tune from memory; if JP1 is set to the tune elements out during receive position, the program waits until forward power is no longer present, then removes all tuning elements. The frequency is saved for future frequency comparison, and the computer reverts to the **Stop** mode.

8.2.2 Antenna Too Long

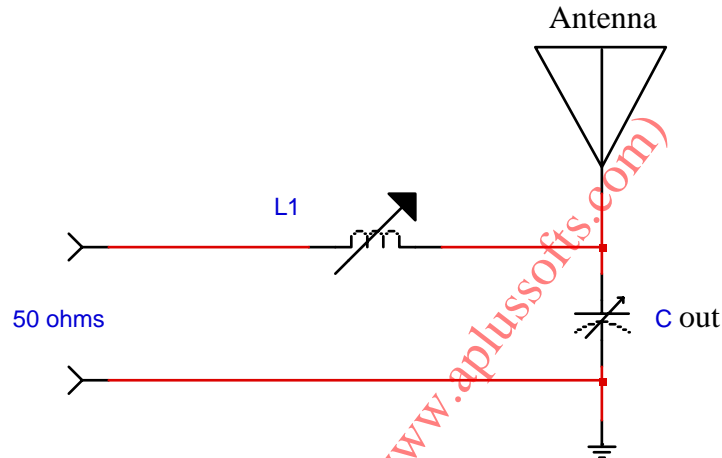

Once the coupler has verified RF power, the tuning sequence proceeds as follows:

- Output capacitance is added until the phases switches to capacitive.
- At this point, series inductance is added until the antenna is no longer capacitive.
- Fine tuning is performed by trying a small amount of input capacitance (this may or may not be required).
- At this point, the program executes the same as step 5 (above).

The preceding gives a simplified program flow on only two possible antenna conditions. Much more complex tuning is normally the case. Further detailed description, however, is beyond the scope of this manual.

8.2.3 JP1—Tuning Elements Out During Receive

(Factory Default Setting: No)

YES In this position the software will retain data required in transmit to match the coupler while removing all tuning elements when no forward power is detected.

SGC SMARTUNER MANUAL 47

NO In this position the coupler will retain the required tuning data and will change nothing whether in receive or transmit.

If typical operation is out of band duplex, **Yes** would be most likely to give better performance. If in band operation is typical and duplex or simplex is the predominant mode of operation, then **No** is usually the better choice.

8.2.4 Jp2—Tune From Memory

(Factory Default Setting: Yes)

YES In this position the coupler will recall data previously saved and try this data before attempting to re-tune. If the data is valid and the VSWR is less than 2:1 the tune is completed. In this position the coupler will save any new data in its memory for any frequency. A new frequency must first be learned, while in this mode, before it can be recalled.

NO In this position, the coupler will not use previously saved tuning data. Each time a different frequency is selected, the coupler will proceed through a complete tuning sequence.

Clearly, the advantage of **Yes** is speed. The coupler will seem to be matched instantly when in this position, if the frequency being used has previously been saved in EEPROM. Disadvantages include a difference in frequency too small for the computer to detect. This would result in recall of valid data that may not necessarily present the best match.

We suggest starting with JP2 in the **Yes** position. If operation is as expected, don't change it.

9.0 SMARTLOCK OPERATION

The SmartLock allows the operator to have additional control over the SMARTUNER. It is not required for normal operation.

9.1 Tune, Tune Lock, and Reset

- | | |
|---------------------------|---|
| Tuned (green LED) | Turns on when the coupler has successfully tuned. |
| Normal / Tune Lock | Toggle switch that allows user to prevent coupler re-tuning by switching to the Tune Lock position. When in the Tune Lock position, the red LED blinks to notify the user that the coupler is locked on the current setting. |

Reset Pushing the red reset button allows the coupler to be reset. This is preferable to the other method of turning the input power off and on.

9.2 Smartlock Notes

The **Tune Lock** function is in most cases unneeded. Inadvertent retuning is a rare occurrence. Retuning may occur when the environment or antenna system has changed. In this case, retuning is within normal operation of the coupler. However, the function is still provided with the SMARTUNER to be used if desired.

10.0 Receiving Antenna Systems

10.1 Receiving Antenna Systems

Traditionally, receiving systems used transistors and transformers as a means of matching the antenna impedance to the radio (See Figure 10.1.1.) This is called an Active Receiving Antenna.

Figure 10.1.1

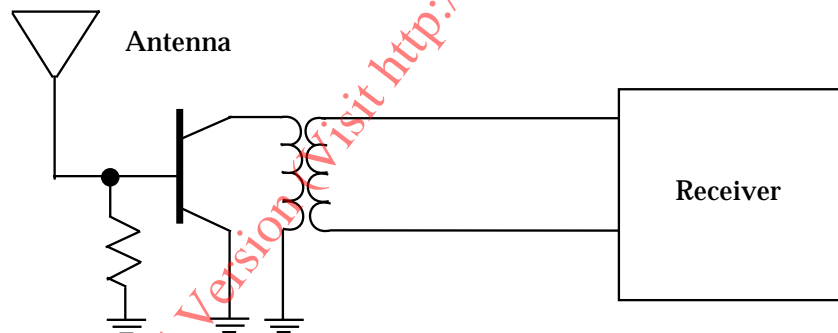

When a SMARTUNER is used, the impedance matching is done more directly, giving greater selectivity to the operator. This system is called an Active Tuned Receiving Antenna (See Figure 10.1.2.) The advantage here is that more of the actual signal energy reaches the receiver allowing for a greater SNR to be achieved.

SGC SMARTUNER MANUAL 49

Figure 10.1.2

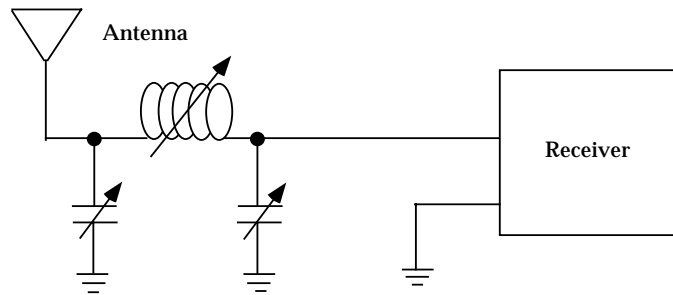

Thus, the SMARTUNER can be used in receiver-only systems to enhance its reception capabilities.

11.0 Troubleshooting the SMARTUNER

Only a small number of installation mistakes can be made. These will fall into one of several categories: ground fault, cable fault, and antenna fault. There is also a slight chance of an electrical fault in the coupler.

When you are troubleshooting the SMARTUNER and you understand that there are three variables, you should change each variable, in sequence, to determine where the problem lies. If you change the ground, antenna, or supply voltage, you are bound to change the performance of the coupler.

11.1 Ground Faults

Common ground faults include faulty counterpoise, indecisive ground, differing resistance, improper bonding, and problems resulting from inaccurate assumptions.

Faulty counterpoise. The most common problem encountered here is when an installation has been made without a proper counterpoise. If the counterpoise is electrically smaller than the antenna, the system may load “upside down”—where the antenna acts as the counterpoise and the counterpoise radiates. When this condition occurs, the operator may encounter “RF Bites” from touching metal objects connected to the counterpoise.

Indecisive ground. A second kind of ground fault occurs when the decision whether the ground or the antenna should radiate is difficult. When this condition is encountered (usually at a frequency where the counterpoise is near resonance), the coupler may cycle repeatedly. This condition may be addressed as follows:

- You may give short bursts of CW and when the coupler stops in a tuned condition, as indicated by the remote tuned LED, you may invoke the SmartLock Tune Lock function, thus forcing the coupler to retain correct settings.

SGC SMARTUNER MANUAL 50

- You may simply change the ground system so that it becomes larger than the antenna at the problem frequency.

Differing resistance. The third kind of ground fault that we encounter occurs when a ground system and an antenna have very different electrical resistance. This happens when you install a very conductive copper antenna wire in an aircraft. When the fuselage is used as a counterpoise, the aluminum must be *much bigger* than would a copper ground because the internal resistance of aluminum is significantly higher than copper.

By the way, this is why we don't like to use aluminum ground wires as radials. Just as when aluminum is used in house wiring, several gauges larger are needed to carry the same amount of current the same need applies here.

Improper bonding. The fourth kind of ground fault you may encounter occurs where the ground is not properly bonded to the coupler. We go to considerable effort to make sure the stainless steel ground stud is well connected to the coupler. In fact, we go so far as to use large braid on the inside of the coupler.

Particularly in automobiles and aircraft, a single ground connection **will not do**. It is mandatory that at least two ground bolt connections be used.

Inaccurate assumptions. The fifth situation to check for is what we call "*dangerous assumptions*" about the ground system. When you bond from the antenna coupler to copper or iron water pipes, you might make an assumption that the water pipes are a good ground. But in many installations, copper pipes are used in the building but a plastic main connects to the municipal system just outside the service entrance. So much for a good ground.

11.2 Antenna Faults

The key to getting the most out of your SMARTUNER is to realize the antenna begins right at the ceramic feed through insulator on the SMARTUNER case. In other words, this is the feed point of your antenna system. Failing to install your coupler accordingly will result in unsatisfactory operation. With this concept in mind, you can easily avoid some of the common troubles with a properly planned installation.

Coaxial cable on output. Coax on the output is probably the single most commonly asked question about the coupler and is the most misunderstood. Let us reiterate: The SMARTUNER was not designed to feed a piece of coax.

Stray ground capacitance. Stray ground capacitance is the next largest cause of malfunctioning installations. If you have a long lead wire from the coupler to a feed-through (on a wall or bulkhead), you significantly increase your chance of problems.

SGC SMARTUNER MANUAL 51

Wire running parallel to a grounded surface may represent a significant capacitance to ground and, just as with coax, this will cause problems.

To give you an idea how these two points can cause problems, let us relate an incident that happened in late 1992. A SMARTUNER user had a coupler installed in a mobile ham radio installation. The coupler could not find a lock on several bands. After going through his installation carefully, the user called SGC for technical support. This user was nearing wit's end.

In working through the logical troubleshooting process with him, we discovered that he had used coaxial feed line from the insulator on the coupler to the antenna feed point. Because he had read about the dangers of capacitance to ground in an earlier edition of this manual, he did not have the coax shield grounded. We had him remove the ungrounded braid and the installation worked fine.

Experiences like this have taught us to be fanatical about using the shortest possible wire and no coax on the output of the coupler.

Another key lesson here is that even if you have a low capacitance lead, a high capacitance antenna will not work well. If you have a whip type antenna, mounted on the back of a van, you will have a large portion of the antenna running right next to grounded sheet metal. This causes a high loss to ground, one reason why we do not recommend CB type whip antennas. The other reason is the base insulation in ball mounts is inadequate for everything but extremely low power.

Long lead lines. If you have a SMARTUNER feeding a 9-foot antenna with a 1-foot feed line located inside a hull or inside a vehicle, you have 10% of the antenna where it will do you no good. If you have more than 5% of the antenna inside a grounded cabin, you will begin to lose performance.

A good rule of thumb is that under one foot of feed line is a good installation, one to two feet aren't very good installations, and over two feet means you are asking for trouble.

“Odd reactance.” The next category of antenna fault is what we call the “odd reactance” problem. Although the SMARTUNER is an exceptionally well-designed product, you may from time to time find an antenna length that just won't quite work right. Generally this occurs when the SMARTUNER is having a tough time making up its mind about which of two tuning solutions is better. If it is a very close call, you can have an antenna which causes cycling and just won't stay locked.

The solution in such cases is to add or subtract a couple of feet of wire from the antenna. This generally cures the problem.

SGC SMARTUNER MANUAL 52

As part of your check-out of an HF system, you should operate on all channels and frequencies which you plan to use on a regular basis to insure the coupler and antenna which you have provided work well.

Antenna insulators. Sporadic operation may be caused by poor antenna insulators. We have seen on sailboats, for example, people trying to save money by expecting the fiberglass hull to act as an insulator and not using a lower insulator. The hull is not a good insulator and a thin layer of wet salt water will degrade the ground further. Similarly, mobile HF users who rely on a poor quality ball-mount find these are especially prone to arc over inside the ball mount where it is difficult to detect.

The point we are making here is simply this: you should have a leakage path of 2 inches at all points on your antenna and especially in the area of the feed point: 10,000 to 30,000 volts of RF energy will not be adequately confined by inexpensive insulators.

11.3 Transmitter Faults

Some vexing problems don't relate directly to the antenna or the ground system but may nonetheless cause difficulties. Here are two of the most common types:

Oscillation. The transmitter may have a tendency to oscillate. The general symptom is that the coupler will work well with another radio but will not tune correctly when the desired radio is in place. The coupler finds a tuning solution, as indicated by the remote tune indicator going on, but then resumes hunting. In a majority of cases this will be caused by an overly sensitive transmitter final amplifier section or by inadequate shielding around the amplifier.

We know of several radios that oscillate relatively easier than most radios because they are housed in a plastic case. A plastic case does not provide an adequate shield for serious RF components. In some of these cases, putting grounded foil around the radio, or changing the radio location and orientation, has changed the symptoms. But if you want quality performance, select a solid radio.

Power supply. Power supplies have been known to cause problems for HF users because they change voltage when the load on them changes. If the transmitter is drawing heavy current, as transmitters do when they are running at peak input power, the voltage to the antenna coupler may change enough to cause the coupler to either drop into a reset mode (under +11 VDC being present) or, the transmitter final amplifier impedance may change greatly, thus changing the tuning solution.

To alleviate this condition, remember to use a power supply that has both adequate current handling capacity and good dynamic regulation. Better yet, use a regulated power supply of an adequate rating.

11.4 A Final Pointer on Troubleshooting

SGC Inc. SGC Building, 13737 S.E. 26th St. Bellevue, WA. 98005 USA

SGC SMARTUNER MANUAL 53

Remember that the SMARTUNER is an excellent piece of equipment that will give outstanding performance. If you have a problem with the coupler finding a tuning solution, you should *change one variable at a time*.

12.0 Further Reading

Further information regarding applications, installation and operation can be downloaded from www.sgcworld.com. These publications include:

- HF User's Guide
- Go Mobile at 500 Watts
- Stealth Antennas
- Smartuner Antenna Coupler Manuals

Trial Version (Visit <http://www.aplussofts.com>)

SGC SMARTUNER MANUAL

SUBJECT INDEX

- Accessories, 9
- Aircraft installation, 22
- Antenna connection, 32
- Antenna coupler—what is it? 1
- Antenna coupler mounting, 32
- Antenna faults, 49
- Antenna installation, 28
- Antenna location, 28
- Antenna selection, 11
- Antenna too long, 45
- Antenna too short, 44
- Antenna types, 11
- Apartment loop antenna, 19
- Backstay antennas, 12
- Base quadra loop, 16
- Base dipole, 16
- Base installation, 14
- Base station grounds, 31
- Caution: high voltages, 4
- Cold temperature installations, 6
- Corrosion, 32
- Coupler configuration, 36
- Coupler mounting, 32
- Covert antennas, 22
- CPU —Central Processing Unit, 40
- Delta loop, 17
- Electrical checkout, 35
- Emergency antennas, 24
- Experience levels of users, 1
- Final pointer on troubleshooting, 50
- Frequency range, 8
- General information, 1
- General notes on antennas, 27
- General notes on couplers, 27
- Ground faults, 48
- Ground systems —general, 29
- High temperature installations, 6
- High voltages: Caution, 4
- Impedance detector, 37
- Indicators, 4
- Information, ready, 10
- Initialization, 40
- Installation with SG-2000, 33
- Jeep installation, 12
- Kite antenna, 24
- LED indicator installation 12 VDC, 34
- LED indicator installation 24 VDC, 34
- Longwire antenna, 12
- Low profile, hidden, 22
- Manual coupler software, 43
- Manual tuning, 33
- Marine grounds, 30
- Marine mounting, 5
- Mechanical design, 5
- Microtune, 41
- Motor vessel installation, 14
- Network configuration, 4
- Overall description, 3
- Parts, 9
- Phase detector, 40
- Program description, 42
- QMS, 6
- Quick start guide, ii
- Recalling settings in memory, 46
- Recommended antennas, 9
- Recreational vehicle (RV) antennas, 20
- Remote installations, 7
- Remote manual tuning, 33
- Remote tune indicator LED, 33
- Schematic diagrams, 36
- SG-105 marine and base station antenna, 11
- SG-203 marine 28 foot whip, 11
- SG-303 high performance 9 foot whip, 11
- SG-2000 to Smartuner coupler connections, 33
- Small loop, 20
- Smartlock, 34
- Smartlock installation, 34
- Specifications, 8
- Storing settings in memory, 36
- Table of contents, iii
- Tactical antenna supports, 25
- Tactical grounds, 25
- Tactical installation, 25
- Technical support, 9
- Transmitter faults, 50
- Troubleshooting, 47
- Tune from memory, 41
- Tuning algorithms, 43
- Tuning elements out during receive, 44
- Tuning paths, 43
- Tuning process, 37
- Upgrade sequence, 8
- V type antenna, 11
- Vehicle grounds, 29
- Vehicle installation, 13
- Vessel groundless loop, 18
- Vessel insulated backstay, 19
- VSWR detector, 37

SGC Inc. SGC Building, 13737 S.E. 26th St. Bellevue, WA. 98005 USA

SG-230 Manual



Notes

Trial Version (Visit <http://www.aplussofts.com>)



SG-230 Manual

Notes

Trial Version (Visit <http://www.aplussofts.com>)

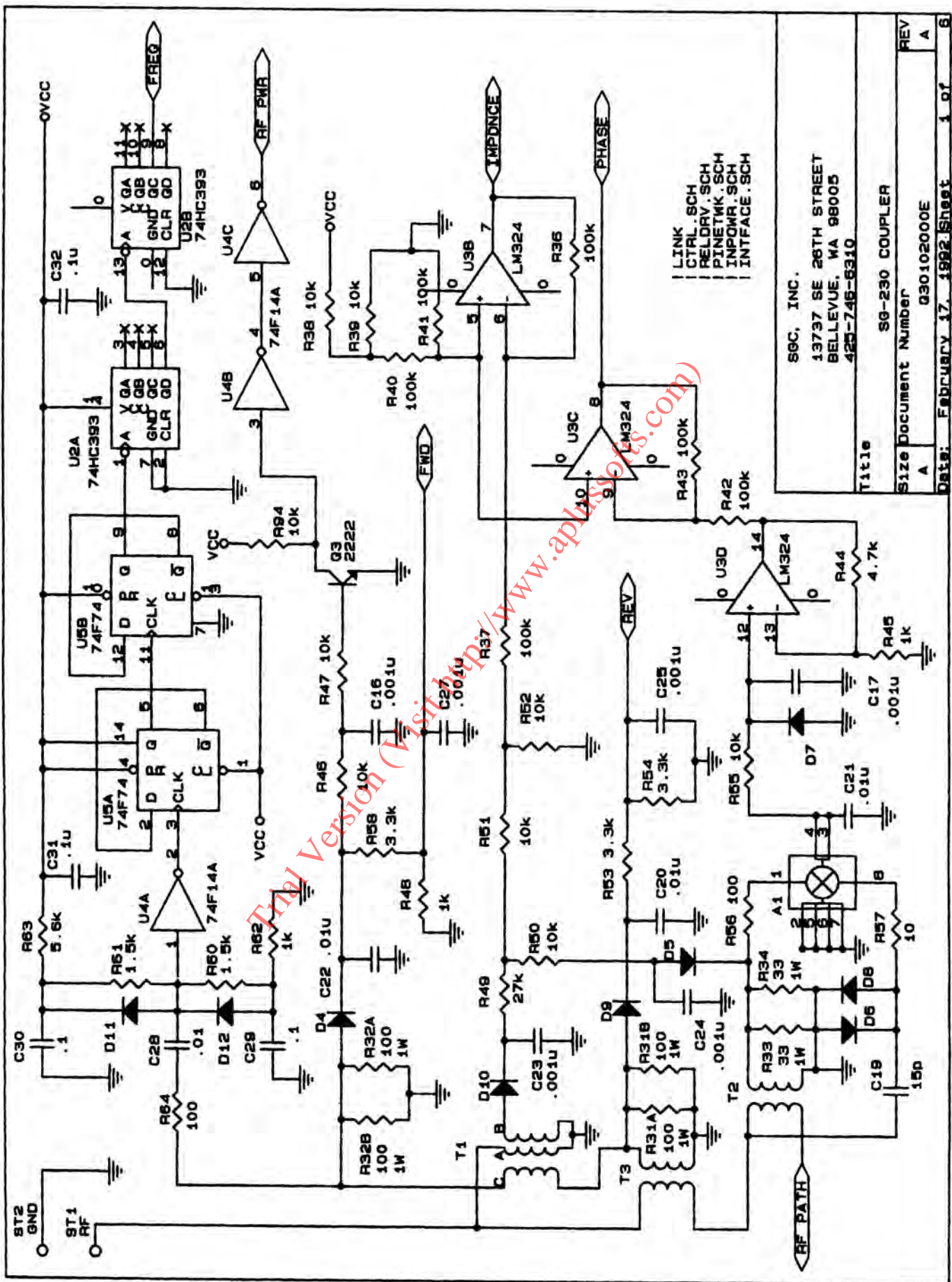

- | LINK.SCH
- | CTRL.SCH
- | RELDRV.SCH
- | PINETWK.SCH
- | INPWNR.SCH
- | INTFACE.SCH

SGC, INC.
 13737 SE 26TH STREET
 BELLEVUE, WA 98005
 425-746-6310

Title SG-230 COUPLER
 Size Document Number A 030102000E
 REV A

Date: February 17, 1992 Sheet 1 of 6

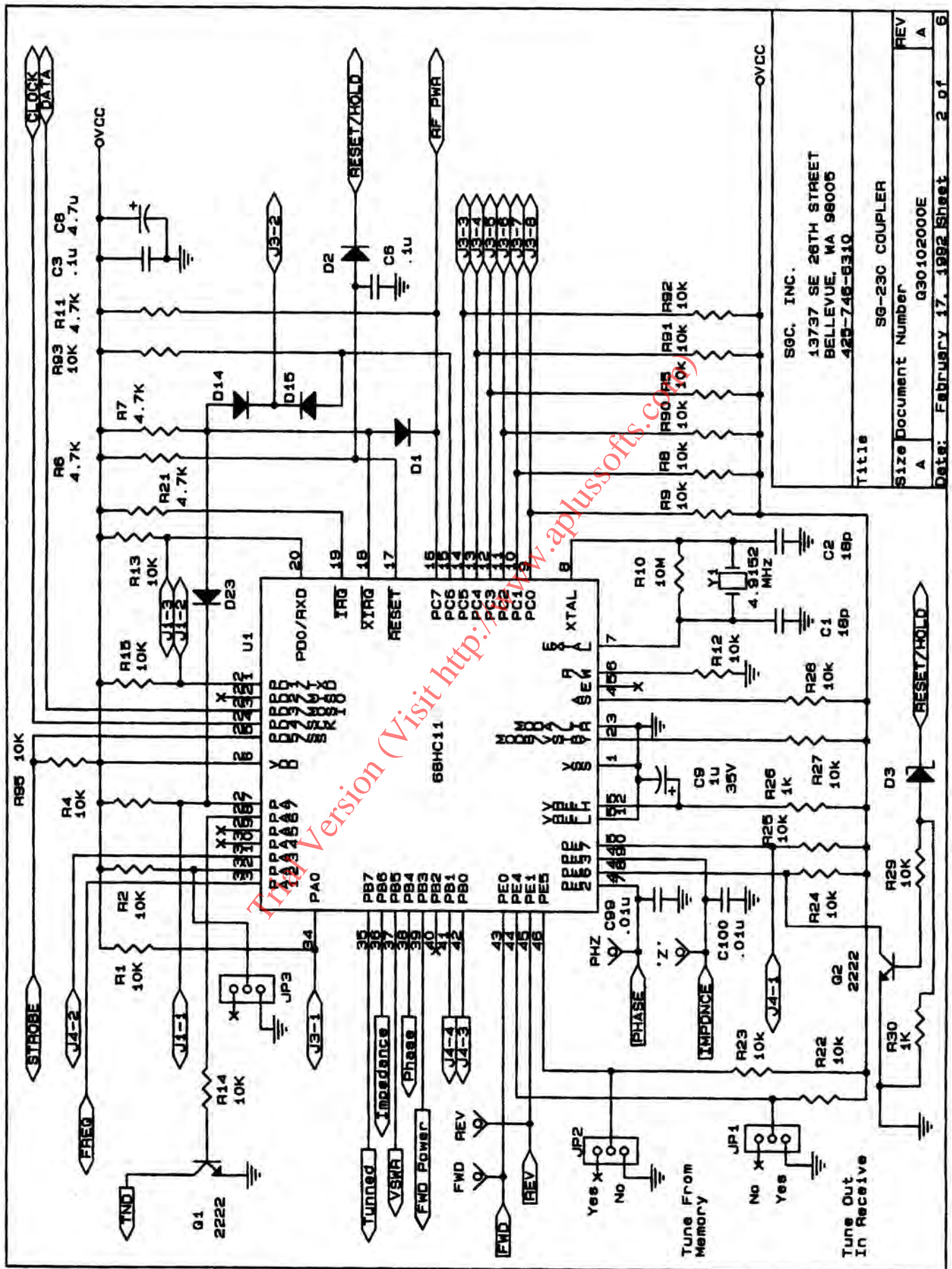

SGC, INC.
 13737 SE 26TH STREET
 BELLEVUE, WA 98005
 425-746-6310

Title	SG-23C COUPLER
Size Document Number	G30102000E
REV	A
Date:	February 17, 1992
Sheet	2 of 6

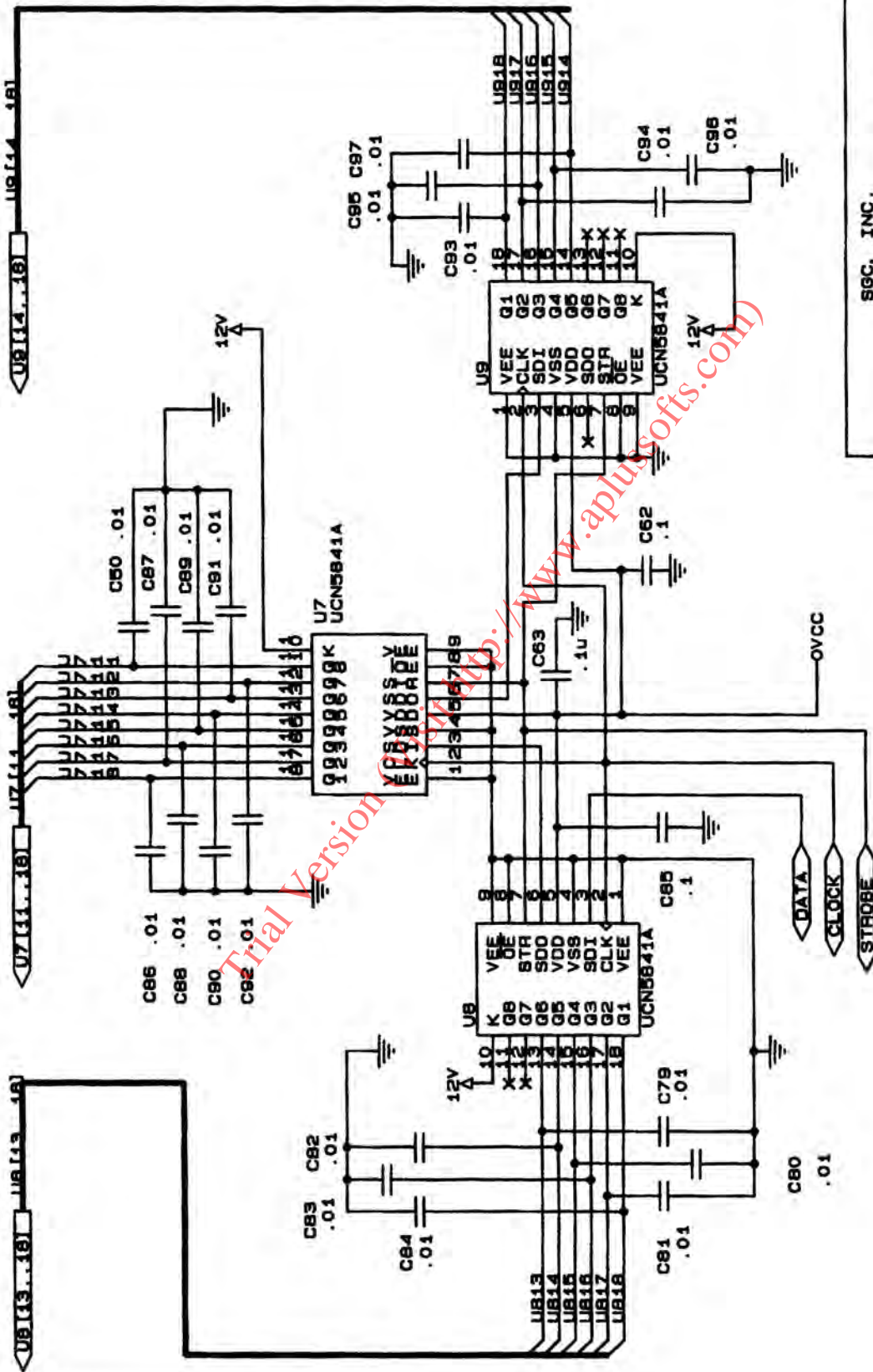

SGC, INC.
 19737 SE 26TH STREET
 BELLEVUE, WA 98005
 425-748-6310

Title		SG-230 COUPLER	
Size		A	
Document Number		G30102000E	
Date:		FEBRUARY 17, 1992	
Sheet		3 of 6	
REV		A	

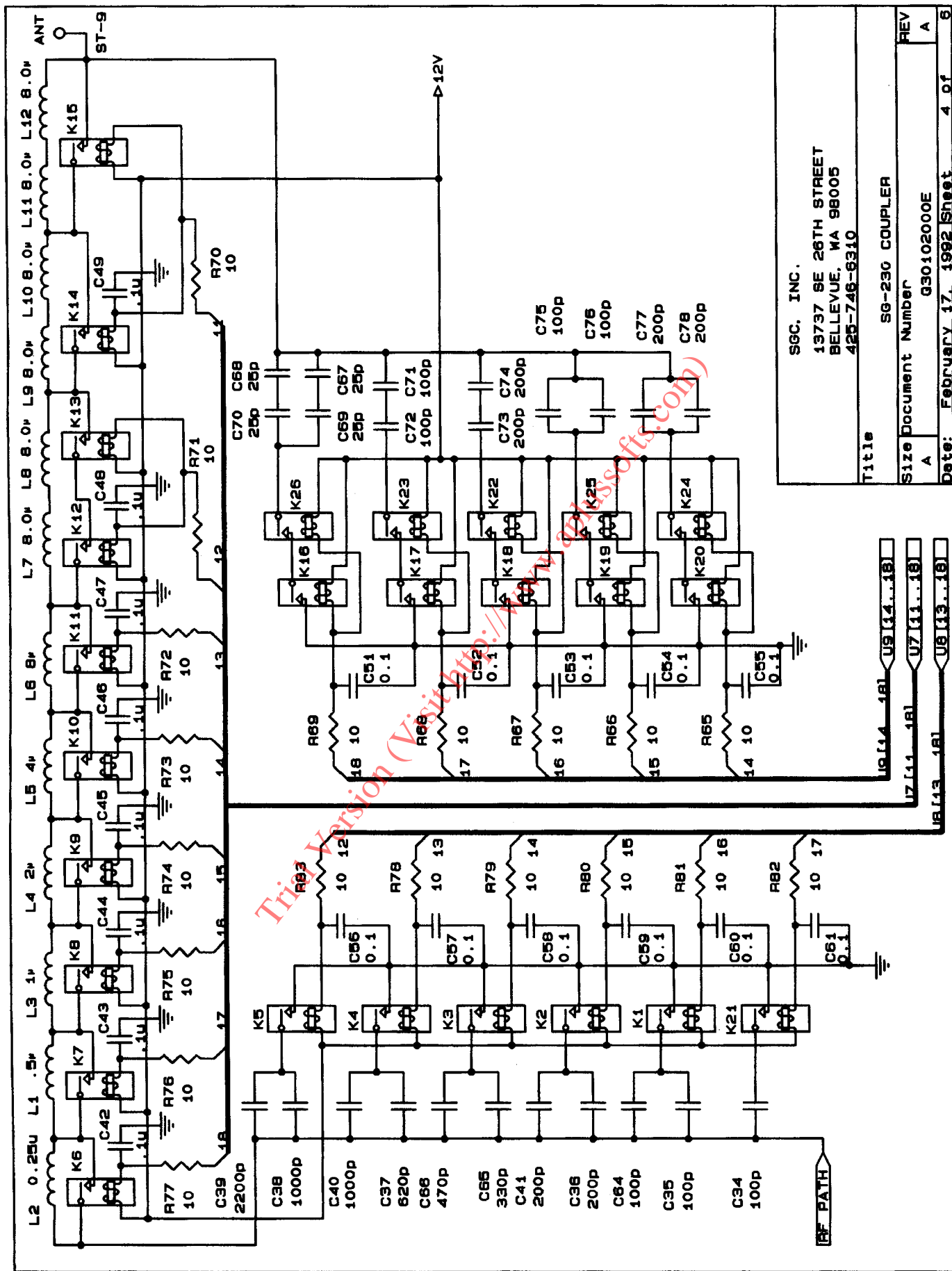

SGC, INC.
 13737 SE 26TH STREET
 BELLEVUE, WA 98005
 425-746-6310

Title: S9-230 COUPLER

Size Document Number: G30102000E

REV: A

Date: FEBRUARY 17, 1992 Sheet 4 of 6

U9 [14..18]

U7 [11..18]

U8 [13..18]

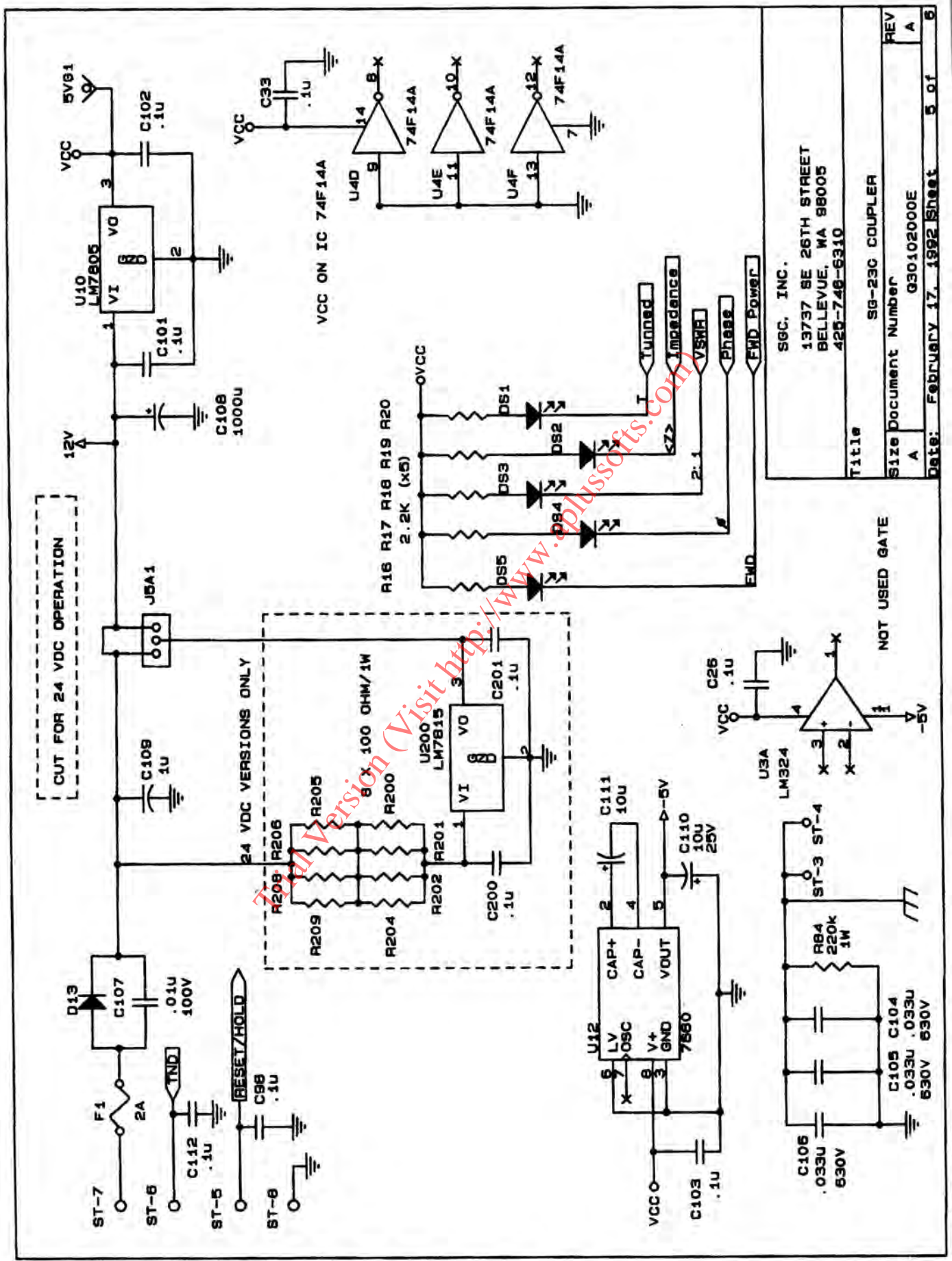

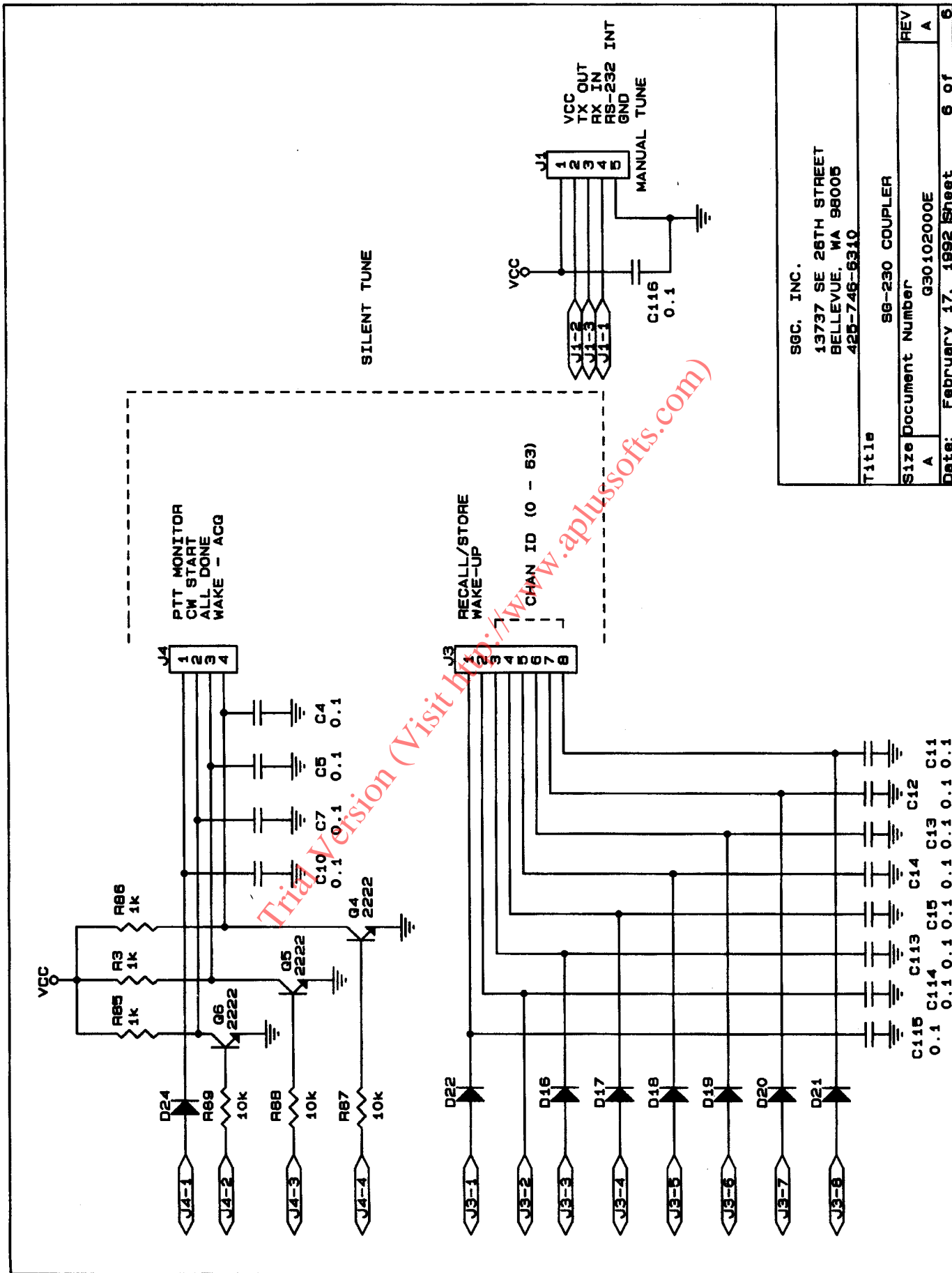

SGC, INC. 13737 SE 26TH STREET BELLEVUE, WA 98005 425-746-6310	
Title	SG-230 COUPLER
Size	Document Number G30102000E
REV	A
Date:	February 17, 1992 Sheet 6 of 6

QMS-7

Antenna Coupler System

Quick Mount System
for mobile HF and VHF use



- QMS-7 offers unsurpassed frequency agility without user intervention
- SG-231 Smartuner automatic antenna coupler, SG-307 extended full-range antenna, and weather resistant QMS-7 package
- 1 to 60 MHz —continuous— instant tuning while you drive
- Rated for use on moving vehicles at up to 75 miles (120km) per hour

It makes no difference where you go or what vehicle you drive, the QMS-7 will provide exceptional auto-tuning with any HF and VHF transceiver.



SGC®
No Compromise Communications

SGC, Inc., P.O. Box 3526 , Bellevue, WA 98009 USA
Tel: 425-746-6310 or 1-800-259-7331 Fax: 425-746-6384
E-mail— sgc@sgcworld.com Web site— <http://www.sgcworld.com>
SGC reserves the right to modify specifications without notice.

© October 2000 SGC, Inc.

The QMS-7 Antenna Coupler System

QMS-7—

Mounting coupler and antenna outside the vehicle reduces engine noise, interference and eliminates feed loss. It can be quickly installed and easily moved from vehicle to vehicle. No drilling or vehicle modifications are required. Industrial suction cups secure the QMS-7 to the vehicle, without damaging the finish, and high strength straps and buckles complete the job and give structural integrity.



Antenna Coupler

SG-231— Smartuner HF/VHF antenna coupler is the working brain inside the QMS-7 system. Use the SG-231 to automatically tune just about any antenna (7 feet minimum) to 3 to 100 watt HF/VHF transceivers from 1 to 60 MHz. It automatically evaluates and switches over 4 million possible combinations of input capacitance, output capacitance, and series inductance to ensure a perfect match between the transceiver and the antenna. The SG-231 Smartuner remembers the chosen frequency and tuning values and will automatically reselect these values—in less than 10 ms—each time you transmit on that frequency. It operates with any HF and VHF transceiver.



Marine and Mobile Antenna

SG-307— a durable and lightweight antenna designed for mobile applications. It's a high efficiency radiator, by virtue of its dual element design. In construction, a single fiberglass whip, helically wound, has a primary resonance at 8 MHz and a secondary resonance at 25 MHz. So at lower frequencies—those under approximately 25 MHz—the SG-307 will vastly outperform a conventional 9-foot whip antenna. The QMS puts the entire antenna system outside the vehicle for high efficiency and low noise.

SG-307 — industrial strength spring and rubber booting allow for 90° flexibility of antenna.

SGC reserves the right to modify specifications without notice.



No Compromise Communications

© SGC, Inc., P.O. Box 3526, Bellevue, WA 98009
USA Tel: 425-746-6310 or 1-800-259-7331
Fax: 425-746-6384
E-mail: sgc@sgcworld.com
Web site: <http://www.sgcworld.com>

Specifications:



QMS-7

Total QMS system weight: 12.5lb. (5.6kg)
Overall case dimensions: 13.5 x 10 x 4.3 inches (34 x 26 x 10 cm)
Housing finish: Black hard anodized
Maximum strap length: 2 ft.
Maximum strap tension: 2000 lb.
Strap width: 1 in.
Maximum allowable vehicle speed: 75 miles (120 km) per hour

SG-231 Smartuner

Frequency range: 1 to 60 MHz
Maximum RF Power: 100 watts
Input Impedance range: 45 to 55
VSWR: Typical—less than 1.4:1
DC input requirements: 13.6 VDC
Input current: Average .9 amps
Random set time: Typical—less than 2 seconds
Recurrent set time: Typical—less than 10 milliseconds
Non-volatile memory addresses: 170 BIN

SG-307 Antenna

Frequency range: 1 to 60 MHz
Maximum RF Power: 150 watts PEP voice or CW
Length: 7 ft., including adjustable ratchet mount and spring
Equivalent: 23-foot antenna
Design: helically wound

QMS Antenna Coupler System

The Quick Mount System
for any mobile HF rig

No Compromise
Communications



- QMS offers unsurpassed frequency agility needing no user intervention
- QMS includes SGC Smartuner automatic antenna coupler, extended full-range antenna, and weather resistant QMS package

QMS Descriptions:

QMS-b2 cat. #55-47
includes the SG-230
(200W)

1.8 to 30 MHz
SG-303 9 ft. antenna

QMS-b3 cat. #55-48
includes the SG-235
(500W)

3.0 to 30 MHz
SG-303 9 ft. antenna

QMS-a7 cat. #55-49
includes the SG-231
(100W)

1.0 to 60 MHz
Includes VHF bands
SG-307 7 ft. antenna
(QMS-7 not shown)



No Compromise Communications

1-800-259-7331

The SGC Building, 13737 S.E. 26th Street, P.O. Box 3526, Bellevue, WA 98009 USA
Phone: 425-746-6310 FAX: 425-746-6384

E-mail: sgc@sgcworld.com Website: <http://www.sgcworld.com>

© October 2000 SGC, Inc.

The QMS Antenna System



Strap the QMS on your favorite family or business vehicle. You'll find it gives any HF-SSB superior frequency agility and exceptional performance.

The SGC Smartuner automatic antenna coupler, the SG-303 extended full-range antenna, and the special exterior QMS mounting package comprise the QMS. Mounting coupler and antenna outside the vehicle reduces engine noise and interference.

It can be quickly installed and easily moved from vehicle to vehicle). No drilling or vehicle modifications are required. Industrial suction cups secure the QMS to the vehicle, without damaging the finish, and high strength straps and buckles complete the job and give structural integrity.

The **SG-303** is a durable and lightweight antenna designed for mobile applications. It's a high efficiency radiator, by virtue of its dual element design. In construction, a single fiberglass whip, helically wound, has a primary resonance at 10 MHz and a secondary resonance at 22 MHz. So at lower frequencies—those under approximately 20 MHz—the SG-303 will vastly outperform a conventional 9-foot whip antenna. The QMS puts the entire antenna system outside the vehicle for high efficiency and low noise.

The **Smartuner** HF antenna coupler is the working brain inside the QMS system. It automatically evaluates and switches 64 input and 32 output capacitance combinations, plus 256 inductance combinations in a network. The result is over a half-million different ways to ensure a perfect match between the transceiver and the antenna. Smartuner remembers the chosen frequency and tuning values and will automatically reselect these values—in less than 10 ms—each time you transmit on that frequency. It operates with any HF transceiver.

- **microprocessor controlled**
- **non-volatile memory**
- **16" D x 12" W x 3" H**
- **1.8 to 30MHz range**
- **water resistant**

(See QMS-7 brochure for more options.)



No Compromise
Communications

The SGC Building, 13737 S.E. 26th Street, P.O. Box 3526,
Bellevue, WA 98009 USA

Phone: 425-746-6310 800-259-7331 FAX: 425-746-6384 425-746-7173
E-mail: sgc@sgcworld.com Website: http://www.sgcworld.com

Specifications:

(QMS-7 specifications included on separate brochure.)

QMS (Quick Mount System)

QMS-b2 cat.# 55-47

QMS-b3 cat.# 55-48

Total QMS system weight:

21 lb.

Overall QMS case dimensions

18 x 12 x 5 in.

Housing finish:

Black hard anodized

Maximum strap length: 5.5 ft.

Maximum strap tension:

2000 lb.

Strap width:

1 in.

Maximum allowable vehicle

speed:

75 miles per hour

SMARTUNERS

SG-230 cat. # 54-12

SG-235 cat. # 54-15

SG-231* cat. # 54-17

SG-237 cat # 54-19

HF Frequency range:

SG-230 1.8 to 30 MHz

SG-235 3.5 to 30 MHz

SG-231* 1.0 to 60 MHz

SG-237 1.8 to 60 MHz

Input Impedance range:

25 to 100

VSWR: Typical—less than 2:1

DC input Voltage: 13.8 VDC
(SG-230 only option: 24 VDC)

Input current: Average .9 amps

SG-235: 1.4 amps

Random set time: Typical—

less than 2 seconds

Recurrent set time: Typical—

less than 10 milliseconds

Non-volatile memory

addresses: SG-230 = 500

SG-235 & SG-231 = 170

SG-303 antenna cat. # 55-27

Frequency range:

1.8 to 30 MHz

Maximum Power:

500 watts PEP voice or CW

Length: 9 ft., including adjustable ratchet mount

Equivalent: 23-foot antenna

Design: helically wound

SG-303 Antenna

with

SGC Couplers

The SG-303, a high performance mobile antenna, is designed and built to operate in rough terrain and extreme climactic conditions. It has a lifetime warranty.

The SG-303 antenna is a light-weight and low-cost mobile antenna for operation between 1.8 and 30 MHz. Nine feet in length overall, it consists of two sections of helically wound whip, mounted on a sturdy professional weatherproof rubber spring. Mounts on an adjustable ratchet mechanism:

- the base adjusts for the best attachment to the vehicle.
- the antenna ratchet permits orienting the whip from vertical to horizontal.

The SG-303 stands up to the wind loading at highway speeds, as well as to rain, ice, and the occasional tree branch.

The SGC line of antenna couplers —the famous SGC “Smartuners”—packed into a sturdy case, mount on the vehicle as close as possible to the antenna lead-through. Each one gives almost any HF-SSB a major boost in range and clarity. The Smartuner “intelligently” tunes any length antenna. No preliminary tuning or adjustment is required, and the Smartuner operates with any HF transceiver in the 1.6—30 MHz range and with output power from 3 to 500 watts.

Be sure to see SGC's revolutionary mobile QMS system for mounting antenna and coupler outside the vehicle.

SGC[®]

The SGC Building 13737 S.E. 26th Street, Bellevue, WA 98005 USA
Box 3526, Bellevue, WA 98009 USA 425-746-6310 or 1-800-259-7331

Fax: 425-746-6384 E-mail: sgc@sgcworld.com Web site: <http://www.sgcworld.com>

SG-303

- Heavy duty rubber encapsulated spring mount
- Heavy duty whip antenna
- Adjustable 4-way ratchets

Smartuners

- Waterproof for all weather
- Built-in test equipment indicator
- 1.6 to 30 MHz range
- 3 to 500 watts (depending on model)

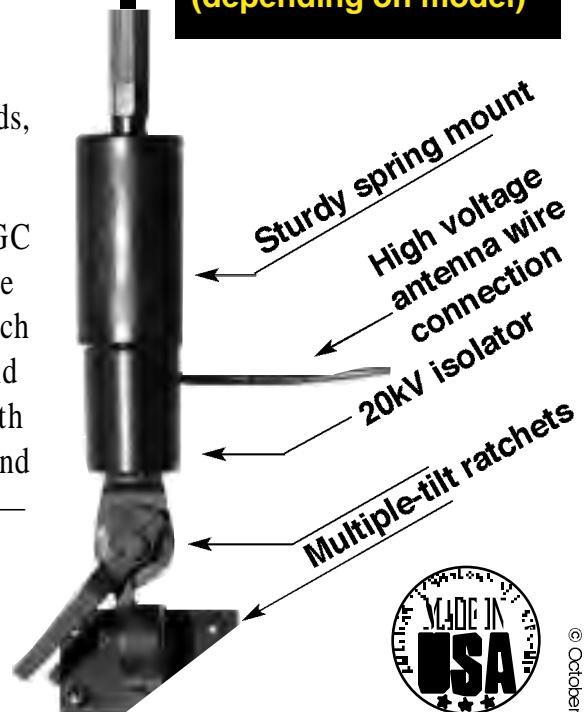

SG-303 Specifications

HF Frequency Ranges:	1.8 to 30MHz
Maximum Output Power:	3 to 500 watts (PEP) voice or CW
Dual Frequency Resonance:	at 12 and 22 MHz
Antenna structure:	Two sections, 50 inches each
Mount:	high voltage insulated 4-way stainless steel ratchet mount
Base:	heavy duty rubber encapsulated spring mount
Feed-through:	high voltage wall feed-through bushing (hole = .890 in.)
Cable:	3 ft. high voltage wire, one end terminated by a round lug

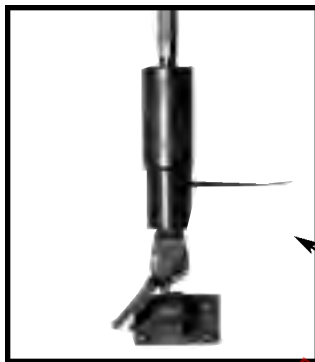

© October 2000, SGC, Inc.

SGC®

No Compromise Communications

The SGC Building, 13737 S.E. 26th Street, P.O. Box 3526,
Bellevue, WA 98009 USA

Phone: 425-746-6310 800-259-7331 FAX: 425-746-6384 425-746-7173

E-mail: sgc@sgeworld.com Web site: <http://www.sgeworld.com>

Combine an SG-303 with an SGC coupler for HF-SSB mobile operation with high radiation performance

Antenna installation. The heavy duty ratchet mount attaches to a flat surface. Mount high voltage cable away from the metal antenna support. Mount the antenna at the highest point of the vehicle. The high voltage waterproof cable feeds through the vehicle body as close to the base of the antenna as possible.

Coupler Installation. The coupler mounts inside the vehicle and close to the base of the antenna. Braided straps make a good ground.

Antenna ratchet mount. The four-way ratchet mount allows the antenna to be adjusted for operation when the vehicle is in motion.

Excellent communication under even adverse weather conditions can be achieved when the vehicle is moving.

Reclining the antenna. When the vehicle is travelling, this will avoid unnecessary exposure to objects like bridges or trees.

Smartuner Specifications

SG-230 - 200 watts

HF Frequency Range:	1.6 to 30MHz
Power Input Range:	3 to 200watts(PEP)
VSWR:	Typical—less than 2:1
DC Input:	+13.6 VDC (24 VDC optional)

SG-231 - 100 watts

HF Frequency Range:	1-60 MHz
Power Input Range:	3 to 100watts(PEP)
VSWR:	Typical—less than 1.4:1
DC Input:	+13.6 VDC (24 VDC optional)

SG-237 - 100 watts

HF Frequency Range:	1.8-60 MHz
Power Input Range:	100watts (PEP)
VSWR:	Typical—less than 1.4:1
DC Input:	+13.8 VDC (24 VDC optional)

SG-235 - 500 watts

HF Frequency Range	1.8 to 30MHz
Power Input Range:	3 to 500 watts(PEP)
VSWR:	Typical—less than 2:1
DC Input:	+13.6VDC

General Specifications

Input Impedance Range:	45 to 55
DC Operating Range:	+10.5 to 15 VDC (24 VDC optional)
Input Current:	Average—9 amps
Random Set Times:	Typical—less than 2 seconds
Recurrent Set Times:	Typical— less than 10 milliseconds
Non-volatile Memory Addresses:	500
Installation:	Any position
Operating Temperature:	-35° to +70°C
Environmental:	Waterproof at immersion of half meter, half hour
Size Overall:	16 D x 12 W x 3H inches 40.6Dx 30.5W x 7.6H centimeters
Weight:	8 pounds (3.5 kilos)
Case Construction:	Plastic ABS weatherproof case

SG-307

**FOR MOBILE
HF AND VHF
USE**

7 Ft. MARINE AND MOBILE ANTENNA (coupler required*)

(Cat.#55-28)

The SG-307 is designed and built to operate in rough terrain and extreme climactic conditions. The SG-307 antenna is a light-weight and low-cost mobile antenna for operation between 1.8 to 60 MHz.

At only seven feet in length overall, the SG-307 is mounted on a sturdy professional weatherproof rubber encapsulated stainless steel spring.



SG-307 stainless steel ratchet mount with rubber encapsulated spring mount

Mounts on an adjustable ratchet mechanism:

- the base adjusts for the best attachment to the vehicle.
- the antenna ratchet permits orienting the whip from vertical to horizontal.

The SG-307 stands up to the wind loading at highway speeds, as well as to rain, ice, and the occasional tree branch.

Accompanying SGC's dedication to customer service and guaranteed product reliability a lifetime warranty is provided with the SG-307 antenna.

SG-307

- **Heavy duty rubber encapsulated spring mount**
- **Adjustable 4-way ratchets**
- **Heavy Duty Whip Antenna**

SG-231 Smartuner (recommended)

- **Waterproof for all weather**
- **1.6 to 60 MHz range**
- **3 to 100 watts**
- **Built-in test equipment indicator**



SGC®

No Compromise Communications

*Antenna must be used with an antenna coupler such as the SG-231
SGC, Inc., P.O. Box 3526 , Bellevue, WA 98009 USA
Tel: 425-746-6310 or 1-800-259-7331 Fax: 425-746-6384
E-mail: sgc@sgcworld.com Web site: <http://www.sgcworld.com>
SGC reserves the right to modify specifications without notice.

SG-231 Smartuner

Use the SG-231 to automatically tune just about any antenna (7 feet minimum) to HF/VHF transceivers from 1 to 60 MHz. It automatically evaluates and switches over 4 million possible combinations of input capacitance, output capacitance, and series inductance to ensure a perfect match between the transceiver and the antenna. The SG-231 Smartuner remembers the chosen frequency and tuning values and will automatically reselect these values—in less than 10 ms—each time you transmit on that frequency. It operates with any HF and VHF transceiver. (Cat. #54-17)



QMS

(Universal Quick Mount HF Antenna System)

Mounting coupler and antenna outside the vehicle reduces engine noise, interference and eliminates feed loss. It can be quickly installed and easily moved from vehicle to vehicle. No drilling or vehicle modifications are required. Industrial suction cups secure the QMS-7 to the vehicle, without damaging the finish, and high strength straps and buckles complete the job and give structural integrity. (Cat. #55-49)

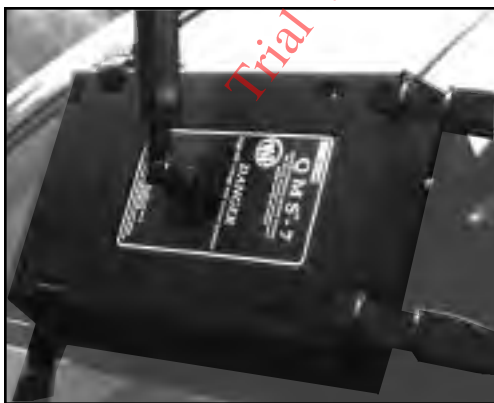

No Compromise Communications

SG-307 Specifications

HF Frequency Ranges:	1.8 to 60MHz
Maximum Output Power:	150 watts PEP voice or CW
Dual Frequency Resonance:	at 8 and 25 MHz
Radiation:	Omnidirectional
Mount:	90° stainless steel base mount rotator and threaded male stud 3/8-24
Base:	Heavy duty stainless steel base spring with rubber boot, Supplied with high voltage isolated mounting base size 10x7x.5 inches
Feed-through:	high voltage wall feed-through bushing (hole = .890 in.)
Cable:	3ft. high voltage wire, one end terminated by a round lug
Catalog Number:	55-28

Antenna must be used with an antenna coupler such as the SG-231

SG-231 Specifications

Frequency Range:	1 to 60MHz
Power Input Range:	3 to 100 watts (PEP)
Input Impedence Range:	45 to 55ohms
VSWR:	Typical - less than 1.4:1
DC Input Requirement:	+13.6VDC
Input Current:	Average-.9 amps
Random Set Times:	Typical- less than 4 seconds
Recurrent Set Times:	Typical-less than 10 milliseconds
Non-volatile Memory Addresses:	170 BINS
Size Overall:	11.5D x 9.5W x 1.7H 29.2D x 24.1W x 4.32 H centimeters
Weight:	3.8 pounds (1.6 kilos)
Case Construction:	Plastic ABS weatherproof case
Catalog Number:	54-17

1-800-259-7331

SGC, Inc., P.O. Box 3526, Bellevue, WA 98009 USA

Tel: 425-746-6310 Fax: 425-746-6384

E-mail: sgc@sgcworld.com Web site: <http://www.sgcworld.com>



SG-230 Smartuner®

Intelligent Tuning

Smartuner® is designed for maximum flexibility. RF "pi" network with over a half million microprocessor combinations.

SmartLock® Option.

Provides two external controls for the SG-230 Smartuner®: Locking function prevents retuning despite changing antenna loads (e.g., from passing trucks, or from driving beneath an overpass); Reset function forces the Smartuner® into the retune cycle until the signal is transmitted again, or allows receiver/scan operation in a broadband antenna mode. (Smartuner® is bypassed). Cat. #54-63



QMS™ Automatic Antenna Coupler System.

Special external mounting system for Smartuner. Gives an incredible boost in receiving and transmitting range-between 3 and 20 db gain! Cat. #55-47.

SG-303 Marine and Mobile Antenna - 8 ft.

(shown installed on QMS box) A high-efficiency-radiator, dual element design. Vastly outperforms a conventional 9 foot whip antenna. Radiation omnidirectional. Cat. # 55-27.



SGC SMARTUNER Family

SG-230



SG-237

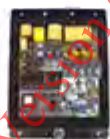

SG-235



SG-231



SG-230

1.6 - 30 MHz
3 to 200watts
Cat. # 54-12

SG-237

1.8-60 MHz
100watts
Cat. #54-19

SG-235

1.6 - 30 MHz
3 to 500watts
Cat. #54-15

SG-231

1 - 60 MHz
3 - 100 watts
Cat. #54-17



No Compromise
Communications

1-800-259-7331

The SGC Building 13737 S.E. 26th Street, Bellevue, WA 98005 USA
Box 3526, Bellevue, WA 98009 USA 425-746-6310 or 1-800-259-7331
FAX: 425-746-6384 E-mail: sgc@sgcworld.com Web site: http://www.sgcworld.com

SG-230 Smartuner® Specifications

HF Frequency Ranges	1.6 to 30MHz
Power Input Range:	3 to 200 watts (PEP)
Input Impedance Range:	45 to 55 ohms
VSWR:	Typical—less than 2:1
DC Input Requirement:	+13.8VDC (24 VDC optional)
DC Operating Range:	10 to 15 VDC (24 VDC optional)
Input Current:	Average—9 amps
Random Set Times:	Typical—less than 2 seconds
Recurrent Set Times:	Typical— less than 10 milliseconds
Non-volatile Memory Addresses:	170
Antenna Length:	8 to 80 feet, 3.3 to 30 MHz 25 to 80 feet, 1.6 to 30 MHz Random lengths up to 300 feet can be used.*
Installation:	Any position
Operating Temperature:	-35° to +70°C
Environmental:	Waterproof at immersion of half meter, half hour
Size Overall:	16 D x 12 W x 3H inches 40.6Dx 30.5W x 7.6H centimeters
Weight:	8 pounds (3.5 kilos)
Case Construction:	Plastic ABS weatherproof case (optional shock-mount tray)
Cable:	SGC special cable, 9 feet coaxial and two power wire input wires, (replaceable by any standard cable), RMT tune and Smartlock® wire
Catalog Number:	54-14

*Under certain limitations.



SG-230 Manual

SGC Equipment Standard Warranty

SGC wishes you to be satisfied with your new equipment purchase. Most SGC products are therefore warranted to be without defect in workmanship or materials for a period of one year from the date of purchase. Proof of a date of purchase is required when requesting warranty service.

The warranty registration card which is furnished with this product should be returned immediately to provide evidence of purchase and to assure receipt of important notices regarding your SGC equipment and related services.

In the event of a defect as defined above, SGC shall, at its option, either repair or replace the product free of charge to the purchaser, provided that:

1. The warranty is limited to the original purchaser and is not assignable.
2. As a condition to obtaining warranty services, purchaser must at its own expense deliver the product to SGC's facility in King County, Washington. If purchaser returns a model that is no longer in stock, SGC reserves the option to replace that unit with another model with comparable capabilities. SGC may choose the carrier for return of the unit, provided that purchaser may request an alternative method of shipment.
3. This warranty is void if your SGC product:
 - a) has not been operated in accordance with all procedures described in the operating instructions;
 - b) has been serviced, adapted or modified without written approval by SGC; or
 - c) is improperly installed, used, or otherwise damaged (including without limitation any damage by fire, smoke or water).
4. There is no warranty coverage for any of the following:
 - a) costs of removing or reinstalling the product when submitted for warranty service;
 - b) incidental, consequential or exemplary damages arising from any defect or failure of the product (except to the extent that applicable state law may not allow exclusions or limitations on such damages, in which case this exclusion may not apply to you);
 - c) any non-performance of the product due to an inadequate or improperly tuned antenna or grounding system;
 - d) transmission range or geographical coverage of the product, which are highly variable in each application;
 - e) routine maintenance, periodic adjustment or performance testing of the product as recommended in the operating instructions;
 - f) normal wear and tear on the product.
5. THIS LIMITED WARRANTY SHALL CONSTITUTE THE SOLE AND EXCLUSIVE WARRANTY FOR YOUR PRODUCT. SGC DISCLAIMS ANY OTHER EXPRESS OR IMPLIED WARRANTY, INCLUDING WITHOUT LIMITATION ANY WARRANTY OF MERCHANTABILITY OR FITNESS FOR ANY PARTICULAR PURPOSE.
6. This limited warranty contains the complete obligations of SGC to purchaser in connection with this product, and it shall supersede all previous oral or written statements or agreements concerning such obligations. This warranty may only be amended by a writing signed by an authorized officer of SGC.
7. After expiration of the warranty herein, SGC may continue to offer repair services to keep your equipment operational. Please inquire as to the prevailing charges for such service.

SG-230



SMARTUNER

(Cat. #54-14)

Automatic Antenna Coupler for all
HF-SSB Bands and Modes



GIVES ALMOST ANY HF-SSB A
MAJOR BOOST IN RANGE AND CLARITY.

Ideally, your HF-SSB radio would always be perfectly tuned to your antenna – for maximum range and clarity. It's a goal that's been easy to wish for, but not so easy to achieve. Until SGC developed the intelligent, micro-processor-controlled, SG-230 Smartuner®.

The SG-230 Smartuner® – intelligently – tunes any length antenna from 8-80 ft! No preliminary tuning or adjustment is required, and the Smartuner will operate with any HF transceiver in the 1.6-30 MHz range and output power from 3 to 200 watts.

Smartuner® automatically evaluates and switches 64 input and 32 output capacitance combinations, plus 256 inductance combinations in a “pi” network—over a half-

million precision matches. Smartuner® then remembers the chosen frequency and tuning values and automatically reselects those values - in less than 10 ms, each time select that frequency.

Flexibility is a key Smartuner® feature, available with a number of attractive options, including a shock mount for military and extreme applications, plus a 24 VDC option.

For maximum range, clarity and flexibility, with just about any HF-SSB, the SG-230 Smartuner® is your smartest choice.

**Microprocessor Controlled, Precision,
Automatic Antenna Tuning
Non-Volatile Memory (170 Addresses)
Waterproof for All Weather**

- **B.I.T.E. (Built In Test Equipment) Indicator**
- **1.6 to 30 MHz Range**
- **3 to 200 Watts Input Power**
- **10 ms Retuning Time**
- **Tunes from 8 to 80 ft. Antennas**
- **For Marine, Aviation, Ham and Para-Military Applications**

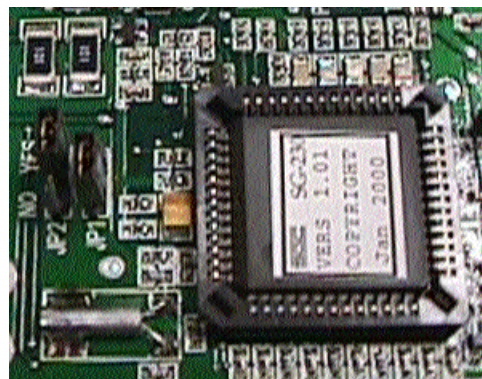

A seven LED B.I.T.E. (Built-in Test Equipment) status display indicates DC power, forward power, phase, two VSWR levels, low impedance and tuned conditions.

SGC®

No Compromise Communications

The SGC Building 13737 S.E. 26th Street, Bellevue, WA 98005 USA
Box 3526, Bellevue, WA 98009 USA 425-746-6310 or 1-800-259-7331

FAX: 425-746-6384 E-mail: sgc@sgcworld.com Web site: www.sgcworld.com